

SECTION N – TOP ENTRY BALL VALVES

Table of Contents

DESCRIPTION	PAGE
Top Entry Ball Valve Features.....	N-3
Materials List	N 4-5
Seat Materials and Seat Designs.....	N 6-7
Pressure-Temperature Ratings.....	N 8-13
Dimensions: Flanged, Standard Port.....	N 14-15
Dimensions: Socket Weld, Standard Port	N 16-17
Dimensions: NPT, Standard Port	N 18-19
Dimensions: Butt Weld, Standard Port	N 20-21
Dimensions: Flanged, Full Port.....	N 22-23
Dimensions: Socket Weld, Full Port.....	N-24
Dimensions: NPT, Full Port	N-25
Dimensions: Butt Weld, Full Port	N-26
Dimensions: Actuator Mounting	N 27-32
Standard Bonnets	N-33
Extended Bonnets.....	N-34
Double Packed Bonnets.....	N-35
Jacketed Valves (Steam, Oil)	N-36
Special Applications	N-37
Flow Coefficients	N-38
Operating Torques	N-39
How to Specify Top Entry Valves	N 40-41
How to Specify Seal Repair Kit for ISO 5211 Bonnet	N-42
Warranty	N-43

SECTION N – TOP ENTRY BALL VALVES

TOP ENTRY BALL VALVES

Features

TOP ENTRY ADVANTAGES:

- Self-Adjusting Seats: Compensate for Wear & Temperature Fluctuations
- Spring Loaded Low Pressure Seals
- Pressure Activated Seating
- Built-In Antistatic Feature
- Simplified In-line Service
- Minimal Potential Leak Paths
- ISO 5211 Mounting Pad

STANDARDS COMPLIANCE

(Most valves within this family of products comply with the requirements of these listed standards.)

ASME B16.5	"Pipe Flanges and Flanged Fittings"
ASME B16.10	"Face to Face Dimensions of Valves" (Except Full Port Valves)
ASME B16.34	"Valves – Flanged, Threaded, and Welding End."
ASME B31.1	"Power Piping"
ASME B31.3	"Chemical Plant and Petroleum Refinery Piping"
ASME B31.8	"Gas Transmission and Distribution Piping Systems"
API 598	"Valve Inspection and Testing"
API 607	"Fire Test – Soft Seated Quarter Turn Valves" (Depending on Seat and Seal Selection)
MSS SP-25	"Standard Marking System for Valves"
MSS SP-61	"Pressure Testing of Steel Valves"
MSS SP-72	"Ball Valves with Flanged or Butt-welded Ends"

NO SURPRISES

Apollo's Top Entry Ball Valves offer more. In addition to the three things everyone has come to expect from Apollo: high quality products, competitive pricing and on time delivery, Apollo Top Entry Valves deliver additional premiums; a broader choice of material for both internal and external components, more optional features to choose from, and selectable seal material combinations all resulting in an expanded serviceable application range.

FIT FOR PURPOSE

These premiums can be combined to create a product uniquely tailored to customer specifications and applications. These additional options allow a valve to be selected without compromising critical performance requirements or operating conveniences and without adding unnecessary features and the costs associated with them.

THE CORRECT DESIGN

The special "V" seating design introduced the self-adjusting seat to the floating ball valve. This design does not rely on the built-in interference of conventional floating ball valves. It provides automatic compensation for pressure, temperature and wear. As these changes occur, the ball and seats are continuously snugged down into the "V" resulting in positive leak-tight shutoff when using resilient seats. Maintaining a low pressure seal had been the most difficult condition for floating ball valves. The wedge effect on the ball and seats down the "V" assures continued low pressure sealing for the life of the seat. All Apollo Top Entry Valves have an "anti-static" feature designed in. All valve configurations also feature blow-out proof stems as standard.

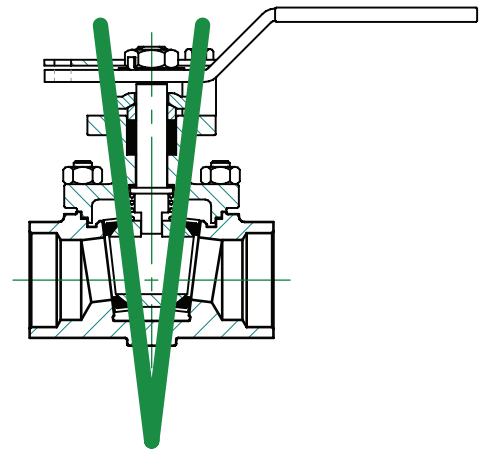

THE RIGHT APPLICATION

Apollo's Top Entry Valves provide simplified in-line maintenance in the most natural way. The valve body is allowed to act as a permanent part of the piping system. Potential leak paths are eliminated with the one piece body. Only the bonnet seal and stem seals remain to be counted. And, with the variety of bonnet gaskets and stem seal arrangements available through the selection of optional features, even these threats can be minimized.

TOP ENTRY BALL VALVES

Materials

BODY MATERIAL:

Body Material Code:	A	B	C	F	G	H	J	K	L
Description	Alloy 20	CF3M SS	Carbon Steel	Inconel (625)	317 SS	Hastelloy C	Duplex (2205)	Super Duplex (2507)	LCC Carbon Steel
Body (all types)	ASTM A351 CN7M	ASTM A351 CF3M	ASTM A216 WCB	ASTM A494 CW6MC	ASTM A351 CG8M	ASTM A494 CW12MW	ASTM A995 CD3MN	ASTM A995 CD3MWCuN	ASTM A352 LCC
Bonnet									
Packing Gland	ASTM A276 Type 316 Stainless Steel								
Gland Plate	316 Stainless Steel								
Gland Plate Bolts	ASTM A193 Grade B8								
Stop	ASTM A276 Type 304								
Stop Bolts	300 Stainless Steel								
Lockplate	302 or 304 Stainless Steel								
Lever Assembly (1/2" - 2")	304 SS w/Vinyl Grip								
Lever Stem Nut (1/2" - 2")	300 Series Stainless Steel								
Lever Assembly (3" - 8")	316 SS Adapter with Stainless Pipe ¹								
Adapter Screw (3" - 8")	300 Series Stainless Steel								
Stem Screw (3" - 8")	300 Series Stainless Steel								
External Grounding Spring	Stainless Steel								
Body Joint Studs	ASTM A193-B8M		ASTM A193-B7				ASTM A193-B8M		
Body Joint Nuts	ASTM A194-Gr.8		ASTM A194-2H				ASTM A194-Gr.8		

NOTE 1: Carbon Steel valves have galvanized pipe handles

Body Material Code:	M	N	P	R	S	T	W	Y
Description	M35-1 (Monel)	Nickel (200)	Carbon	AL-6XN	Stainless Steel	Titanium	254 SMO	Hastelloy B
Body (Flanged ends)					ASTM A351-CF8M			
Body (Buttweld, Socket weld, and screwed ends)	ASTM A494 M35-1	ASTM A494 CZ100	ASTM A217 C12	ASTM A351 CN3MN AL-6XN	ASTM A351-CF3M	ASTM B367 C3	ASTM A351 CK3MCuN	ASTM A494 N12MV
Bonnet					ASTM A351-CF8M			
Packing Gland	ASTM A276 Type 316 Stainless Steel							
Gland Plate	316 Stainless Steel							
Gland Plate Bolts	ASTM A193 Grade B8							
Stop	ASTM A276 Type 304							
Stop Bolts	300 Stainless Steel							
Lockplate	302 or 304 Stainless Steel							
Lever Assembly (1/2" - 2")	304 SS w/Vinyl Grip							
Lever Stem Nut (1/2" - 2")	300 Series Stainless Steel							
Lever Assembly (3" - 8")	316 SS Adapter with Stainless Pipe							
Adapter Screw (3" - 8")	300 Series Stainless Steel							
Stem Screw (3" - 8")	300 Series Stainless Steel							
External Grounding Spring	Stainless Steel							
Body Joint Studs	ASTM A193-B8M							
Body Joint Nuts	ASTM A194-Gr.8							

TRIM (INTERNAL) MATERIAL:

Trim Material Code:	A	B	D	E	F	H	J	K
Description	Alloy 20	316L SS	Hastelloy C Stem, M35-1 Ball	410 SS	Inconel (625)	Hastelloy C	Duplex (2205)	Super Duplex (2507)
Ball	ASTM A351-CN7M or ASTM B473-CB-3	ASTM A351-CF3M or ASTM A276-316L	ASTM A494-M35-1 or ASTM B164-K400 N04400	ASTM A276-410	ASTM B446 N06625 or ASTM A494 GR.CW6MC	ASTM A494-CW12MW or ASTM B574-C276	ASTM A479/A276 UNS S31803 or ASTM A995 GR. CD3MN	ASTM A479/A276 UNS S32760 or ASTM A995 GR. CD3MWCuN
Stem	ASTM B473-CB-3 N08020	ASTM A276-316L	ASTM B574-C276	ASTM A276-410 COND.A	ASTM B446 N06625	ASTM B574-C276	ASTM A479/A276 S31803	ASTM A479/A276 S32760
Seat Ring(s) (from bar, tube or pipe depending on availability)	ASTM B473-CB-3 N08020	ASTM A276-316L	ASTM B574-C276	ASTM A269-316 or A276-316/316L or A312-316	ASTM B446 N06625	ASTM B574-C276	ASTM A479/A276 S31803	ASTM A479/A276 S32760
Internal Spring (5, 6, 8, C, D, G, J, L, M, N, U seats)	Inconel X-750	ASTM A312-Type 316		ASTM A312-Type 316	Inconel X-750			
Internal Spring (4, 9, B, H seats)	Inconel X-750		ASTM B574 Hastelloy C	Inconel X-750		ASTM B574 Hastelloy C	Inconel X-750	

TOP ENTRY BALL VALVES

Materials

TRIM (INTERNAL) MATERIAL (CONT'D):

Trim Material Code:	M	N	R	S	T	W	Y
Description	M35-1	Nickel (200)	AL-6XN	Stainless Steel	Titanium	254 SMO	Hastelloy B
Ball	ASTM A494-M35-1 or ASTM B164-K400 N04400	ASTM A494-CZ100 or ASTM B160-200	ASTM B691 N08367 or ASTM A351 CN3MN	ASTM A351-CF8M or ASTM A276- 316/316L A312-316	ASTM B367-Gr C3 or ASTM B348 Gr. 2,3,or 4	ASTM A351 CK3MCuN	ASTM B335 N10665 or ASTM A494-N-12MV
Stem	ASTM B164-K400 N04400	ASTM B160-200	ASTM B691 N08367		ASTM B348 Gr. 2,3,or 4	ASTM A182-F44 UNS S31254	ASTM B335 N10665
Seat Ring(s) (from bar, tube or pipe depending on availability)	ASTM B164-K400	ASTM B160-200	ASTM B691 N08367	ASTM A269-316 ASTM A276- 316/316L or ASTM A312-316	ASTM B348 Gr. 2,3,or 4	ASTM A182-F44 UNS S31254	ASTM B335 N10665
Internal Spring (5, 6, 8, C, D, G, J, L, M, N, U seats)	Inconel X-750		Inconel X-750	ASTM A312- Type 316	ASTM B348 Gr. 2,3,or 4	Inconel X-750	Hastelloy B-2
Internal Spring (4, 9, B, H seats)			Inconel X-750				

SEAT & SEALS MATERIAL:

Seat Code:	4	5	6	8	9
Seat	Carbon Graphite	55% Bronze, 5% Moly Filled PTFE	UHMWPE	Unfilled PEEK	CERAMIC (Seats & Ball)
Seat O-ring	Not Applicable				
Stem Packing	Flexible Graphite				
Bonnet Gasket	Spiral Wound Flexible Graphite				
Stem Bearing	Nitronic® 60	PEEK	PEEK	PEEK	Nitronic® 60
Default Suffix	24			24	

Seat Code:	B	C	D	G	H
Seat	Carbon Reinforced PEEK	PFA	60% Stainless Filled PTFE	PCTFE	High Temp. Graphite
Seat O-ring	Not Applicable				
Stem Packing	Flexible Graphite			RPTFE	Flexible Graphite
Bonnet Gasket	Spiral Wound Flexible Graphite			RPTFE (150/300) Spiral Wound PTFE (600)	Spiral Wound Flexible Graphite
Stem Bearing	PEEK	PEEK	PEEK	PEEK	Nitronic® 60
Default Suffix	24			01	24

Seat Code:	J	L	M	N	U
Seat	API 607 PFA Fire Seat	API 607 Multiseal Fire Seat	TFM Multiseal	Nylon	UHMWPE
Seat O-ring	PFA	Multiseal Ring	N/A	Nylon	Not Applicable
Stem Packing	Flexible Graphite	Flexible Graphite	PTFE	Flexible Graphite	
Bonnet Gasket	Spiral Wound Flexible Graphite	Spiral Wound Flexible Graphite	RPTFE (150/300) Spiral Wound PTFE (600)	Spiral Wound Flexible Graphite	
Stem Bearing	PEEK	PEEK	PEEK	Nylon	PEEK
Default Suffix	24	24	01	24	

TOP ENTRY BALL VALVES

Seat Materials and Seat Designs

SEAT CODE "G" (PCTFE)

Polychlorotrifluoroethylene is typically used in cryogenic applications. High resistance to inorganic corrosive liquids, including oxidizing acids. Resistant to most organic solvents except some highly halogenated and aromatic materials. (Figure 1) See Pressure-Temperature Chart 3, page 12.

SEAT CODE "L" (TFM MULTISEAL)

API-607 fire-safe design.

This seat design has been successfully tested to the requirements of API 607. The Multiseal seat is fully confined by a metallic seat holder which provides a secondary seal in the event of the loss of the primary TFM seal during a fire. The torque characteristics will be the same as in the #M seats. (Figure 3) See Pressure-Temperature Chart 1, page 11.

SEAT CODE "M" (TFM MULTISEAL)

Apollo's Multiseal is a modified PolyTetraFluoroEthylene (PTFE) that maintains the exceptional chemical resistance and heat resistance properties of conventional PTFE. (Figure 1) See Pressure-Temperature Chart 1, page 11.

SEAT CODE "C" (PFA)

Perfluoroalkoxy seats withstand the effects of polymeric monomers such as butadiene and styrene. (Figure 2) See Pressure-Temperature Chart 1, page 11.

SEAT CODE "J" (PFA)

API-607 fire-safe design

Perfluoroalkoxy seats withstand the effects of polymeric monomers such as butadiene and styrene. This seat design has been successfully tested to the requirements of API 607. The PFA seat is fully confined by a metallic seat holder which provides a secondary seal in the event of the loss of the primary PFA seal during a fire. The torque characteristics will be the same as in the #C seats. (Figure 3) See Pressure-Temperature Chart 1, page 11.

SEAT CODE "5" (55% BRONZE / 5% MOLY BRTFE)

Specifically intended for steam applications. Also applicable to abrasive and throttling applications because of the heavy loading of reinforcing materials and the presence of the inner ring. However, chemical compatibility may be a limiting factor in the application of this seat.

(Figure 2) See Pressure-Temperature Chart 2, page 11.

SEAT CODE "D" (50% STAINLESS STEEL SRTFE)

Intended for abrasive and throttling applications because of the heavy loading of reinforcing materials and the completely confined seat. (Figure 2) See Pressure-Temperature Chart 1, page 11.

SEAT CODE "6" (UHMWPE)

Ultra High Molecular Weight Polyethylene offers good abrasion resistance making it suitable for use in high solids or slurry applications. These seats are completely confined by a metallic seat holder enhancing their performance in abrasive services. This seat is frequently specified in services where fluorine off-gassing in even the slightest amounts is objectionable. Examples of these services are food, tobacco processing, and nuclear services. (Figure 2) See Pressure-Temperature Chart 4, page 12.

Figure 1
Seat Design 1

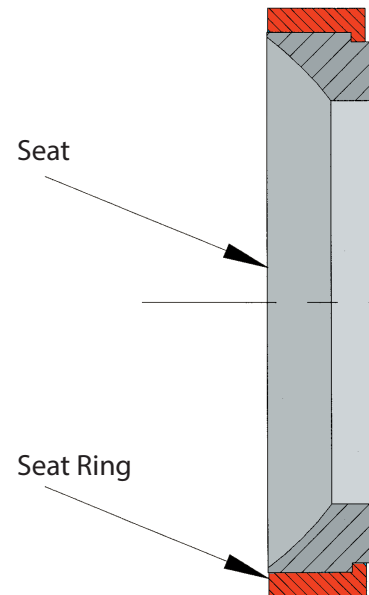
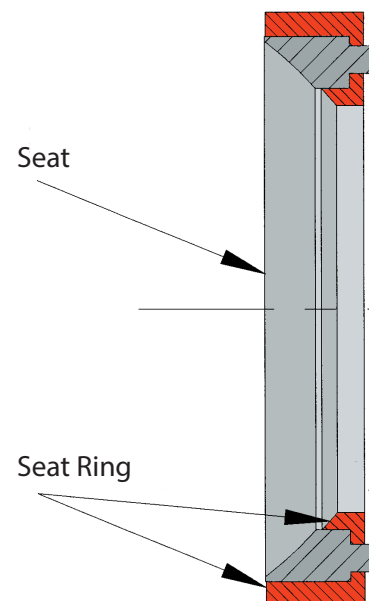

Figure 2
Seat Design 2



TOP ENTRY BALL VALVES

Seat Materials and Seat Designs

Figure 3
Seat Design 3

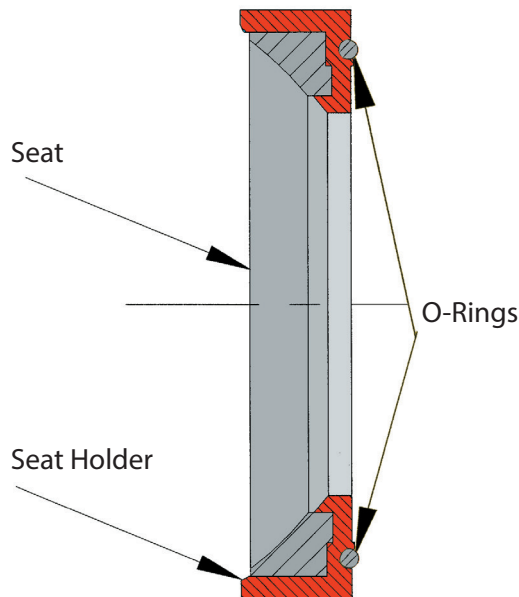
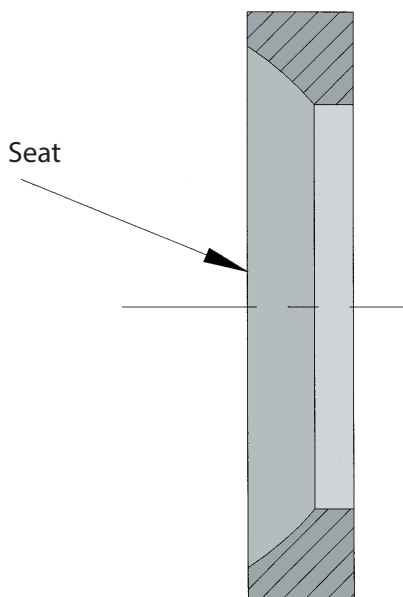

Figure 4
Seat Design 4



SEAT CODE "U" (UHMWPE)

Exhibits the same characteristics as the #6 seat with the exception that it utilizes the inner seat ring to enhance performance in abrasive services. UHMWPE should be used with caution in the presence of solvents, and the operating torque can be expected to be 30% higher than that of the PTFE based seat materials. (Figure 1) See Pressure-Temperature Chart 4, page 12.

SEAT CODE "8" (PEEK)

PEEK (PolyEtherEtherKetone) offers a high strength alternative to RPTFE, resistant to creep and cold flow. This seat offers good abrasion resistance. Higher in cost, this material offers similar chemical resistance to PTFE but should be checked on application. Operating torque tend to be 40% higher than RPTFE. Ball stop recommended. (Figure 2) See Pressure-Temperature Chart 5, page 13.

SEAT CODE "B" (CARBON REINFORCED PEEK)

Carbon Reinforced PEEK provides improved abrasion resistance when compared to the unfilled variety. Higher in cost, this material offers a broader temperature range than PTFE with similar chemical resistance but should be checked on application. Operating torque tends to be 40% higher than PTFE. Ball stop recommended. (Figure 2) See Pressure-Temperature Chart 5, page 13.

SEAT CODE "4" (CARBON GRAPHITE)

Designed for high temperature applications. A ball stop is required in applications above 500°F. Maximum service temperature is limited to 750°F in oxidizing applications. This seat like all rigid seat materials does not necessarily provide "bubble tight" shut-off. Most test standards have allowable leakage rates or list "classes" of shut-off for this type of seat. Be aware of the system design requirements when specifying this or any rigid seat. Ball stop recommended. (Figure 1) See Pressure-Temperature Chart 2, page 11.

SEAT CODE "H" (HIGH TEMPERATURE GRAPHITE)

Designed for very high temperature applications. A ball stop is required in applications above 500°F. Maximum service temperature is limited to 1000°F. This seat like other rigid seat materials does not provide "bubble tight" shut-off. This seat is not as abrasion resistant as the #4 version. Be aware of the system design requirements when specifying this or any rigid seat. Ball stop recommended. (Figure 1) See Pressure-Temperature Chart 2, page 11.

SEAT CODE "9" (CERAMIC)

Working in conjunction with a ceramic ball, this seat outperforms all other materials in throttling and abrasive applications. It possesses excellent chemical resistance. A ball stop is recommended for all applications. This seat like all rigid seat materials does not necessarily provide "bubble tight" shut-off. Most test standards have allowable leakage rates or list "classes" of shut-off for this type of seat. Be aware of the system design requirements when specifying this or any rigid seat. (Figure 4) See Pressure-Temperature Chart 6, page 13.

TOP ENTRY BALL VALVES

Pressure-Temperature Ratings

Temp °F	Valve Body Rating ¹ – psi								
	ASTM A216 Grade WCB ² Carbon Steel			ASTM A351 Grade CF8M ³ (close wrought equivalent is 316 SS)			ASTM A351 Grade CF3M (close wrought equivalent is 316L SS)		
	Class 150	Class 300	Class 600	Class 150 ⁴	Class 300	Class 600	Class 150	Class 300	Class 600
-20 to 100	285	740	1480	275	720	1440	230	600	1200
200 F	260	680	1360	235	620	1240	195	510	1020
300 F	230	655	1310	215	560	1120	175	455	910
400 F	200	635	1265	195	515	1025	160	420	840
500 F	170	605	1205	170	480	955	150	395	785
600 F	140	570	1135	140	450	900	140	370	745
650 F	125	550	1100	125	440	885	125	365	730
700 F	110	530	1060	110	435	870	110	360	720
750 F	95	505	1015	95	425	855	110	355	705
800 F	80	410	825	80	420	845	80	345	690
850 F	65	320	640	65	420	835			
900 F	50	230	460	50	415	830			
950 F	35	135	275	35	385	775			
1000 F	20	85	170	20	365	725			
1050 F				20	360	720			
1100 F				20	305	610			
1150 F				20	235	475			
1200 F				20	185	370			
1250 F				20	145	295			
1300 F				20	115	235			
1350 F				20	95	190			
1400 F				20	75	150			
1450 F				20	60	115			
1500 F				15	40	85			

Temp °C	Valve Body Rating ¹ – bar								
	ASTM A216 Grade WCB ² Carbon Steel			ASTM A351 Grade CF8M ³ (close wrought equivalent is 316 SS)			ASTM A351 Grade CF3M (close wrought equivalent is 316L SS)		
	Class 150	Class 300	Class 600	Class 150 ⁴	Class 300	Class 600	Class 150	Class 300	Class 600
-29 to 38 C	19.6 bar	51.1 bar	102.1 bar	19.0 bar	49.6 bar	99.3 bar	15.9 bar	41.4 bar	82.7 bar
50 C	19.2 bar	50.1 bar	100.2 bar	18.4 bar	48.1 bar	96.2 bar	15.3 bar	40.0 bar	80.0 bar
100 C	17.7 bar	46.6 bar	93.2 bar	16.2 bar	42.2 bar	84.4 bar	13.3 bar	34.8 bar	69.6 bar
150 C	15.8 bar	45.1 bar	90.2 bar	14.8 bar	38.5 bar	77.0 bar	12.0 bar	31.4 bar	62.8 bar
200 C	13.8 bar	43.8 bar	87.6 bar	13.7 bar	35.7 bar	71.3 bar	11.2 bar	29.2 bar	58.3 bar
250 C	12.1 bar	41.9 bar	83.9 bar	12.1 bar	33.4 bar	66.8 bar	10.5 bar	27.5 bar	54.9 bar
300 C	10.2 bar	39.8 bar	79.6 bar	10.2 bar	31.6 bar	63.2 bar	10.0 bar	26.1 bar	52.1 bar
325 C	9.3 bar	38.7 bar	77.4 bar	9.3 bar	30.9 bar	61.8 bar	9.3 bar	25.5 bar	51.0 bar
350 C	8.4 bar	37.6 bar	75.1 bar	8.4 bar	30.3 bar	60.7 bar	8.4 bar	25.1 bar	50.1 bar
375 C	7.4 bar	36.4 bar	72.7 bar	7.4 bar	29.9 bar	59.8 bar	7.4 bar	24.8 bar	49.5 bar
400 C	6.5 bar	34.7 bar	69.4 bar	6.5 bar	29.4 bar	58.9 bar	6.5 bar	24.3 bar	48.6 bar
425 C	5.5 bar	28.8 bar	57.5 bar	5.5 bar	29.1 bar	58.3 bar	5.5 bar	23.9 bar	47.7 bar
450 C	4.6 bar	23.0 bar	46.0 bar	4.6 bar	28.8 bar	57.7 bar			
475 C	3.7 bar	17.4 bar	34.9 bar	3.7 bar	28.7 bar	57.3 bar			
500 C	2.8 bar	11.8 bar	23.5 bar	2.8 bar	28.2 bar	56.5 bar			
538 C	1.4 bar	5.9 bar	11.8 bar	1.4 bar	25.2 bar	50.0 bar			
550 C				1.4 bar	25.0 bar	49.8 bar			
575 C				1.4 bar	24.0 bar	47.9 bar			
600 C				1.4 bar	19.9 bar	39.8 bar			
625 C				1.4 bar	15.8 bar	31.6 bar			
650 C				1.4 bar	12.7 bar	25.3 bar			
675 C				1.4 bar	10.3 bar	20.6 bar			
700 C				1.4 bar	8.4 bar	16.8 bar			
725 C				1.4 bar	7.0 bar	14.0 bar			
750 C				1.4 bar	5.9 bar	11.7 bar			
775 C				1.4 bar	4.6 bar	9.0 bar			
800 C				1.2 bar	3.5 bar	7.0 bar			
816 C				1.0 bar	2.8 bar	5.9 bar			

1 Ratings per ASME B16.34 - 2009

2 WCB: Upon prolonged exposure to temperatures above 800°F (425°C), the carbide phase of steel may be converted to graphite. Permissible, but not recommended for prolonged usage above 800°F (425°C)

3 CF8M: At temperatures above 1000°F (538°C), use only when the carbon content is 0.04% or higher.

4 CF8M Class 150: Flanged End valve ratings terminate at 1000°F (538°C)

TOP ENTRY BALL VALVES

Pressure-Temperature Ratings

Temp °F	Valve Body Rating ¹ – psi								
	ASTM A351 Grade CN7M (close wrought equivalent is Alloy 20)			ASTM A494 Grade CW-12MW (close wrought equivalent is Hastelloy® C)			ASTM A494 Grade M-35-1 (close wrought equivalent is Monel®)		
	Class 150	Class 300	Class 600	Class 150	Class 300	Class 600	Class 150	Class 300	Class 600
-20 to 100	230	600	1200	230	600	1200	230	600	1200
200 F	200	520	1035	210	550	1105	200	525	1050
300 F	180	465	930	200	520	1040	190	490	980
400 F	160	420	845	190	490	980	180	475	945
500 F	150	390	780	170	465	925	170	475	945
600 F	140	360	720	140	440	880	140	475	945
650 F				125	430	860	125	475	945
700 F				110	420	835	110	470	940
750 F				95	410	820	95	465	930
800 F				80	400	800	80	460	915
850 F				65	395	785	65	375	755
900 F				50	385	775	50	275	550
950 F				35	380	760			
1000 F				20	365	725			

1 Ratings per ASME B16.34 - 2009

Temp °C	Valve Body Rating ¹ – bar								
	ASTM A351 Grade CN7M (close wrought equivalent is Alloy 20)			ASTM A494 Grade CW-12MW (close wrought equivalent is Hastelloy® C)			ASTM A494 Grade M-35-1 (close wrought equivalent is Monel®)		
	Class 150	Class 300	Class 600	Class 150	Class 300	Class 600	Class 150	Class 300	Class 600
-29 to 38 C	15.9 bar	41.4 bar	82.7 bar	15.9 bar	41.4 bar	82.7 bar	15.9 bar	41.4 bar	82.7 bar
50 C	15.4 bar	40.1 bar	80.3 bar	15.6 bar	40.6 bar	81.3 bar	15.4 bar	40.2 bar	80.5 bar
100 C	13.5 bar	35.3 bar	70.6 bar	14.5 bar	37.8 bar	75.6 bar	13.8 bar	35.9 bar	71.9 bar
150 C	12.3 bar	32.0 bar	64.1 bar	13.7 bar	35.9 bar	71.7 bar	12.9 bar	33.7 bar	67.5 bar
200 C	11.3 bar	29.4 bar	58.7 bar	13.0 bar	33.9 bar	67.9 bar	12.5 bar	32.7 bar	65.4 bar
250 C	10.4 bar	27.2 bar	54.4 bar	12.1 bar	32.3 bar	64.5 bar	12.1 bar	32.6 bar	65.2 bar
300 C	9.7 bar	25.4 bar	50.8 bar	10.2 bar	30.7 bar	61.5 bar	10.2 bar	32.6 bar	65.2 bar
325 C	9.3 bar	24.4 bar	48.8 bar	9.3 bar	30.1 bar	60.1 bar	9.3 bar	32.6 bar	65.2 bar
350 C				8.4 bar	29.4 bar	58.8 bar	8.4 bar	32.6 bar	65.1 bar
375 C				7.4 bar	28.7 bar	57.4 bar	7.4 bar	32.4 bar	64.8 bar
400 C				6.5 bar	28.3 bar	56.5 bar	6.5 bar	32.1 bar	64.2 bar
425 C				5.5 bar	27.7 bar	55.3 bar	5.5 bar	31.6 bar	63.3 bar
450 C				4.6 bar	27.2 bar	54.4 bar	4.6 bar	26.9 bar	53.8 bar
475 C				3.7 bar	26.8 bar	53.5 bar	3.7 bar	20.8 bar	41.5 bar
500 C				2.8 bar	26.3 bar	52.6 bar			
538 C				1.4 bar	25.2 bar	50.0 bar			

1 Ratings per ASME B16.34 - 2009

TOP ENTRY BALL VALVES

Pressure-Temperature Ratings

Temp °F	Valve Body Rating ¹ – psi								
	ASTM A351 CK3MCuN (close wrought equivalent is 254 SMO)			ASTM A351 CG8M (close wrought equivalent is 317SS)			ASTM B367 C3 (close wrought equivalent is Titanium)		
	Class 150	Class 300	Class 600	Class 150	Class 300	Class 600	Class 150	Class 300	Class 600
-20 to 100 F	290	750	1500	275	720	1440	290	635	1275
200 F	260	745	1490	235	620	1240	260	540	1085
300 F	230	665	1335	215	560	1120	220	440	880
400 F	200	615	1230	195	515	1025	175	350	705
500 F	170	580	1160	170	480	955	145	290	585
600 F	140	555	1115	140	450	900	120	235	475
650 F	125	545	1095	125	440	885			
700 F	110	540	1085	110	435	870			
750 F	95	530	1065	95	425	855			
800 F				80	420	845			
850 F				65	420	835			
900 F				50	415	830			
950 F				35	385	775			
1000 F				20	365	725			

1 Ratings per ASME B16.34 - 2009

Temp °C	Valve Body Rating ¹ – bar								
	ASTM A351 CK3MCuN (close wrought equivalent is 254 SMO)			ASTM A351 CG8M (close wrought equivalent is 317SS)			ASTM B367 C3 (close wrought equivalent is Titanium)		
	Class 150	Class 300	Class 600	Class 150	Class 300	Class 600	Class 150	Class 300	Class 600
-29 to 38 C	20.0 bar	51.7 bar	103.4 bar	19.0 bar	49.6 bar	99.3 bar	20.0 bar	44.0 bar	87.9 bar
50 C	19.5 bar	51.7 bar	103.4 bar	18.4 bar	48.1 bar	96.2 bar	19.6 bar	42.8 bar	85.6 bar
100 C	17.7 bar	50.7 bar	101.3 bar	16.2 bar	42.2 bar	84.4 bar	17.7 bar	36.4 bar	72.9 bar
150 C	15.8 bar	45.9 bar	91.9 bar	14.8 bar	38.5 bar	77.0 bar	15.0 bar	30.0 bar	60.1 bar
200 C	13.8 bar	42.7 bar	85.3 bar	13.7 bar	35.7 bar	71.3 bar	12.3 bar	24.9 bar	49.6 bar
250 C	12.1 bar	40.5 bar	80.9 bar	12.1 bar	33.4 bar	66.8 bar	10.3 bar	20.8 bar	41.5 bar
300 C	10.2 bar	38.9 bar	77.7 bar	10.2 bar	31.6 bar	63.2 bar			
325 C	9.3 bar	38.2 bar	76.3 bar	9.3 bar	30.9 bar	61.8 bar			
350 C	8.4 bar	37.6 bar	75.3 bar	8.4 bar	30.3 bar	60.7 bar			
375 C	7.4 bar	37.4 bar	74.7 bar	7.4 bar	29.9 bar	59.8 bar			
400 C	6.5 bar	36.5 bar	73.3 bar	6.5 bar	29.4 bar	58.9 bar			
425 C				5.5 bar	29.1 bar	58.3 bar			
450 C				4.6 bar	28.8 bar	57.7 bar			
475 C				3.7 bar	28.7 bar	57.3 bar			
500 C				2.8 bar	28.2 bar	56.5 bar			
538 C				1.4 bar	25.2 bar	50.0 bar			

1 Ratings per ASME B16.34 - 2009

Contact Factory
INCONEL 625 ASTM A494-GR CW6MC
NICKEL 200 ASTM A494-CZ100

TOP ENTRY BALL VALVES

Pressure-Temperature Ratings

CHART 1

PFA, TFM, SRTFE – PRESSURE-TEMPERATURE RATINGS

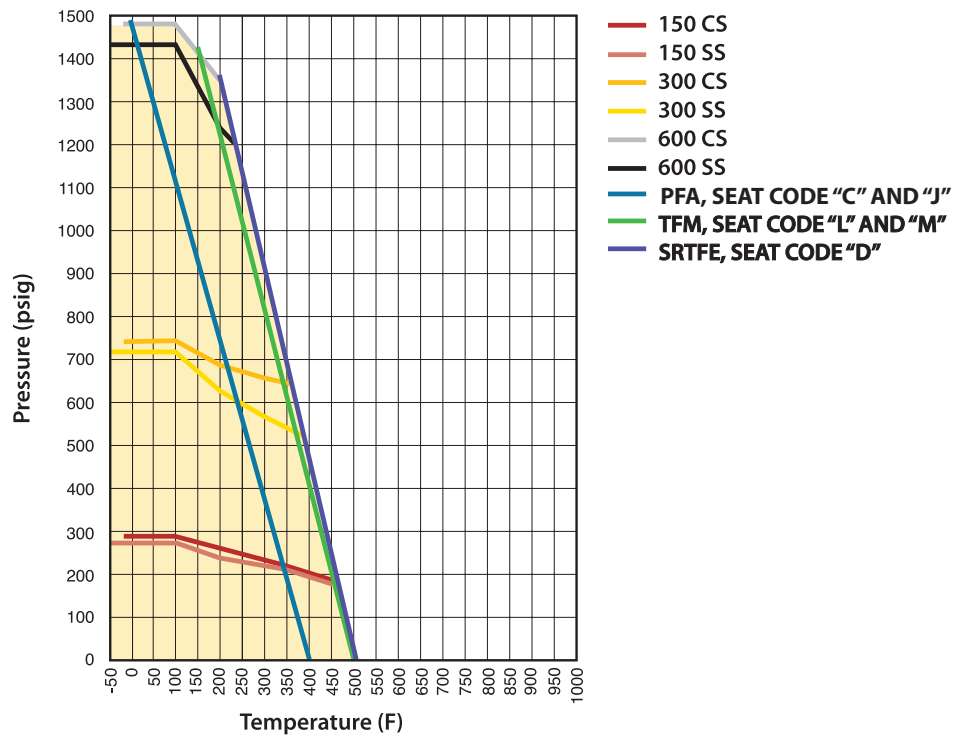
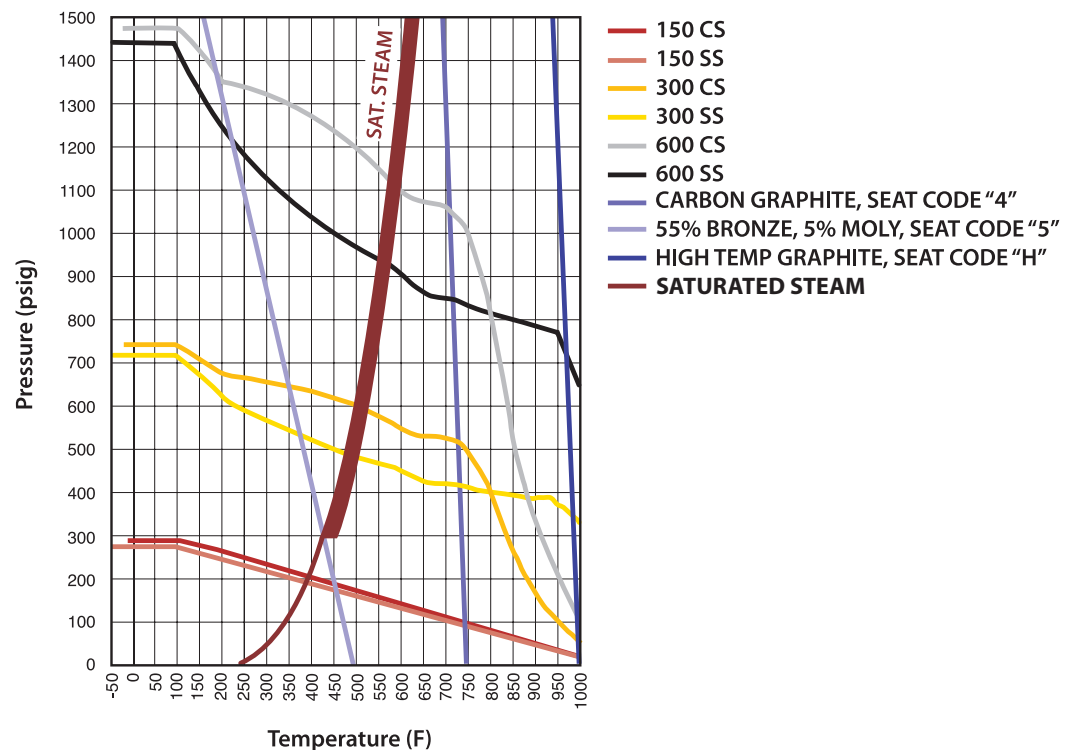

CHART 2

GRAPHITE, BRONZE-MOLY - PRESSURE-TEMPERATURE RATINGS
STEAM RATED SEATS



TOP ENTRY BALL VALVES

Pressure-Temperature Ratings

CHART 3

NYLON, PCTFE – PRESSURE-TEMPERATURE RATINGS

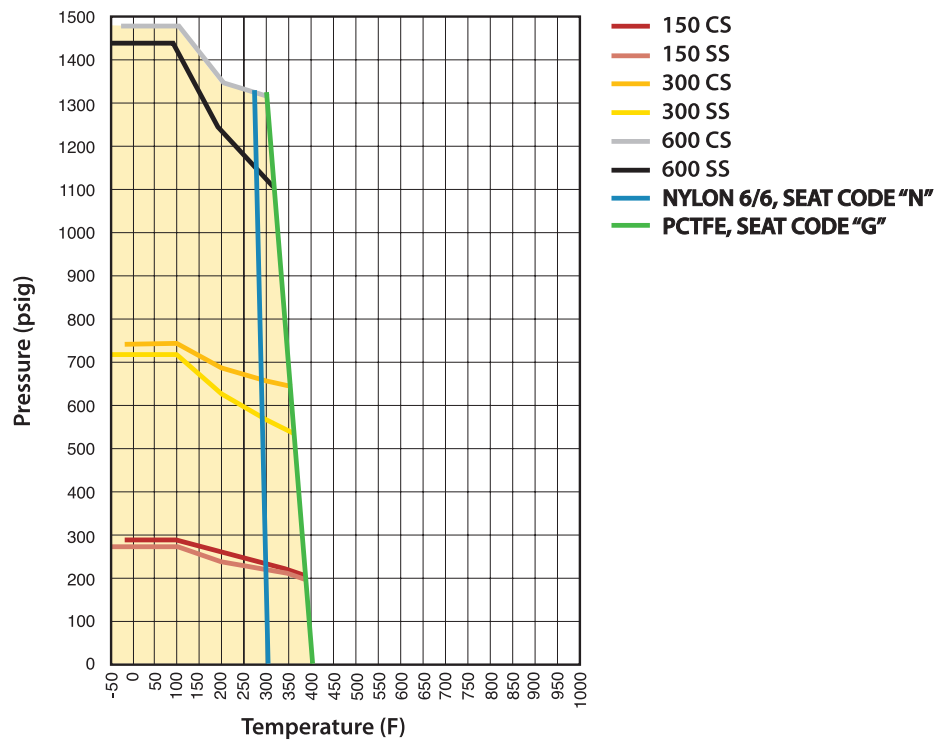
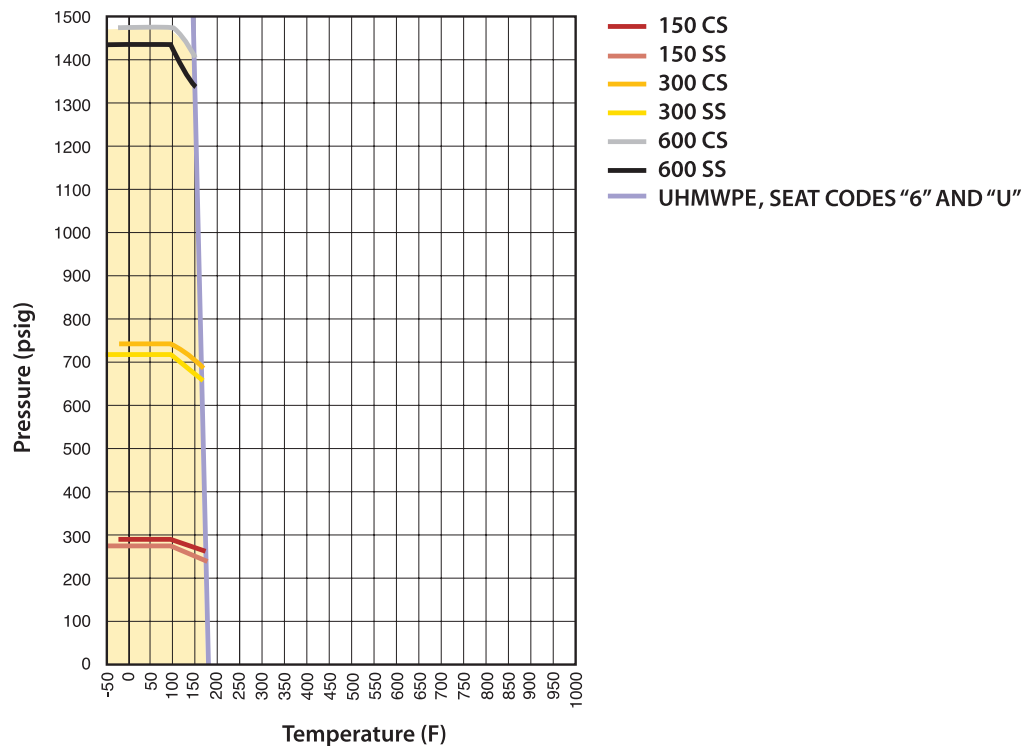

CHART 4

UHMWPE SEATS – PRESSURE-TEMPERATURE RATINGS



TOP ENTRY BALL VALVES

Pressure-Temperature Ratings

CHART 5

PEEK SEATS – PRESSURE-TEMPERATURE RATINGS

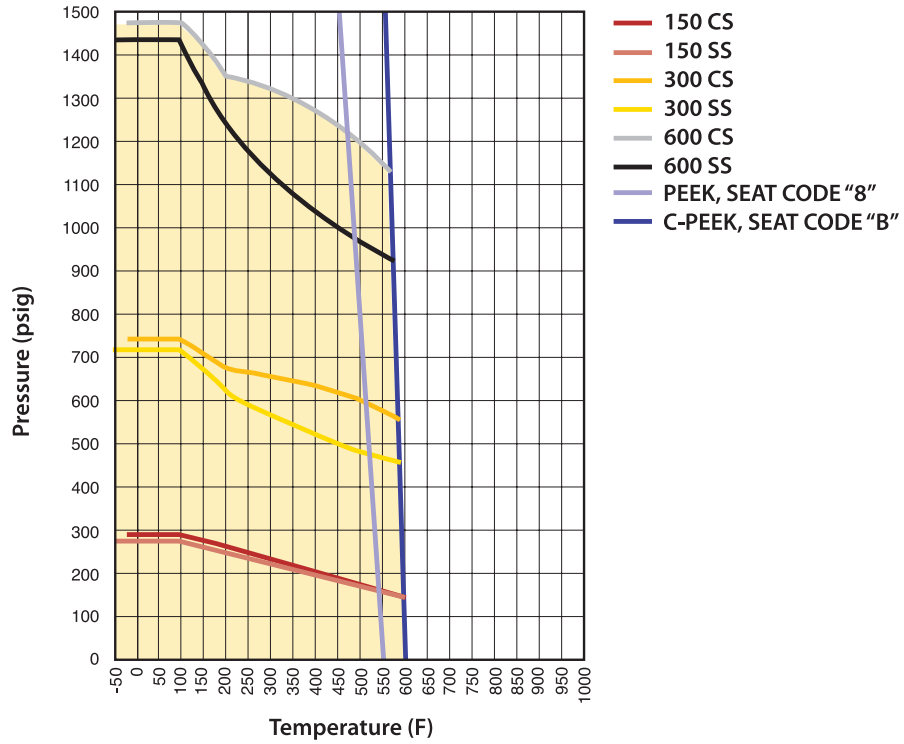
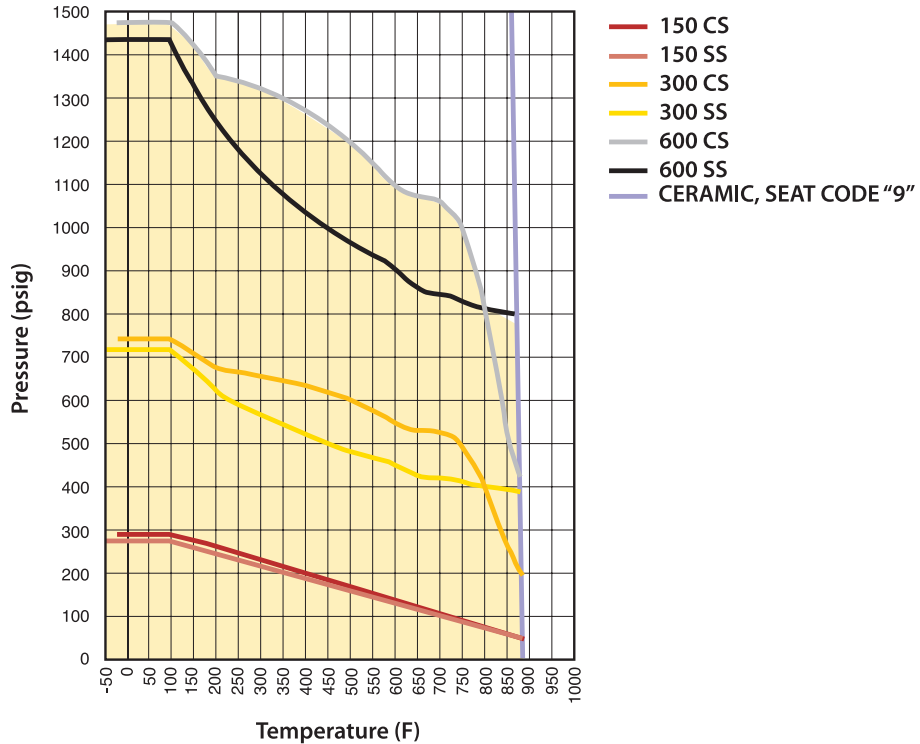

CHART 6

CERAMIC SEATS – PRESSURE-TEMPERATURE RATINGS



ASME CLASS, FLANGED, STANDARD PORT

Dimensions

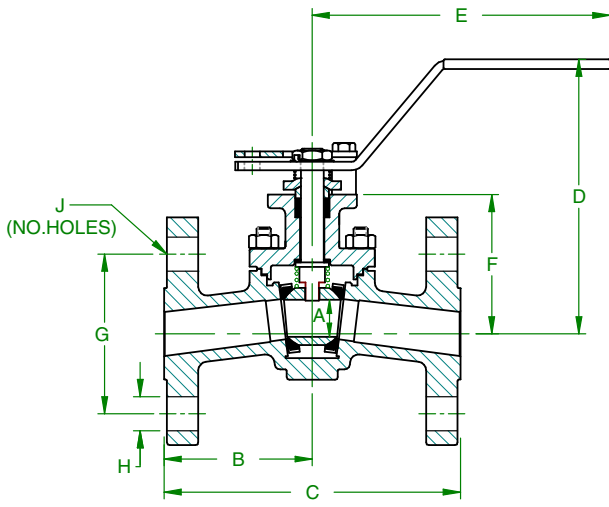

FIGURE 1

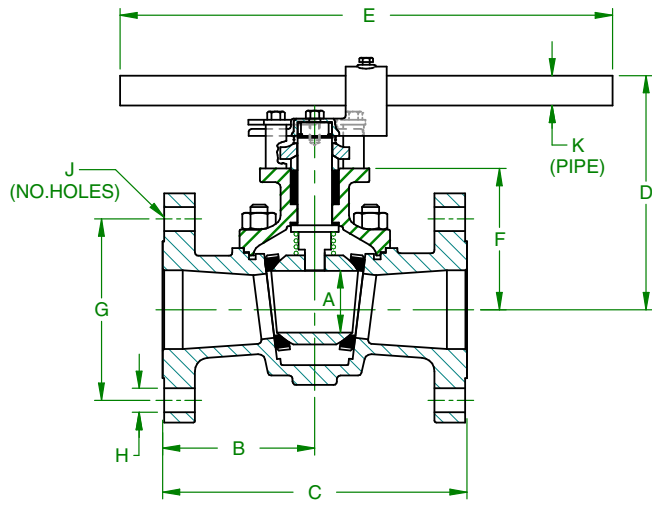

FIGURE 2

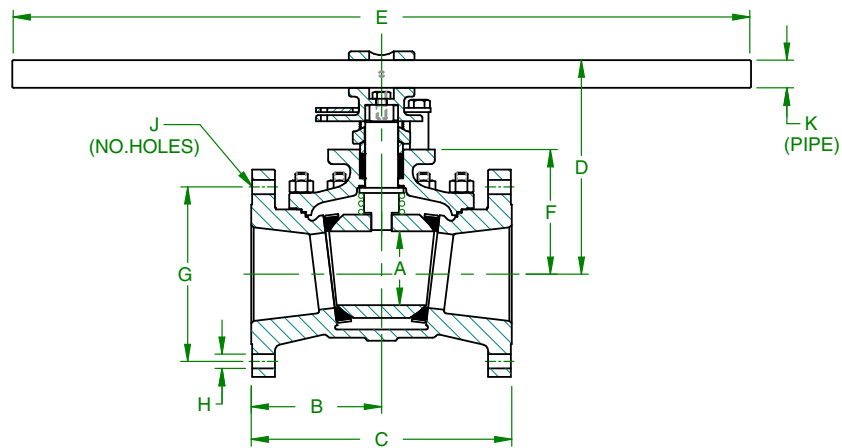

FIGURE 3

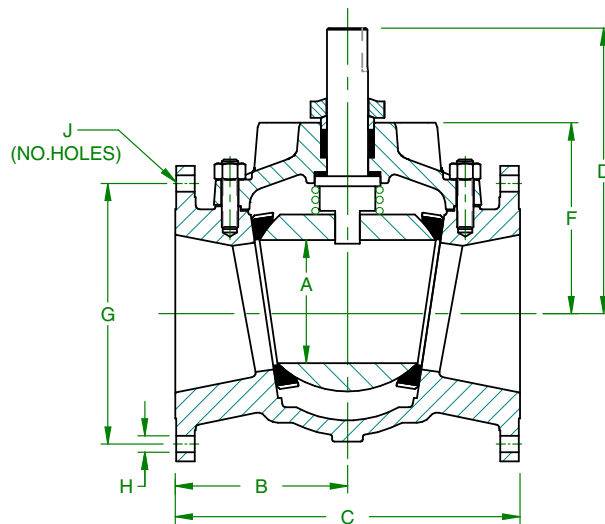

FIGURE 4

ASME CLASS, FLANGED, STANDARD PORT

Dimensions

ASME CLASS 150, FLANGED, STANDARD PORT Dimensions in Inches

	Size	A	B	C	D	E	F	G	H	J	K
FIGURE 1	1/2"	0.81	2.85	5.69	5.85	6.56	2.88	2.38	0.62	4	NA
	3/4"	0.81	2.31	4.62	5.91	6.56	2.94	2.75	0.62	4	NA
	1"	0.81	2.50	5.00	5.94	6.56	2.97	3.12	0.62	4	NA
	1.5"	1.17	3.25	6.50	5.63	6.65	3.41	3.87	0.62	4	NA
	2"	1.50	3.50	7.00	6.54	8.40	4.24	4.75	0.75	4	NA
FIGURE 2	3"	2.25	4.00	8.00	8.55	18.00	5.16	6.00	0.75	4	3/4" SCH.40
	4"	3.00	4.50	9.00	8.68	30.00	5.29	7.50	0.75	8**	3/4" SCH.40
FIGURE 3	6"*	4.50	7.75	15.50	13.04	45.00	7.59	9.50	0.87	8	1.25" SCH.80
FIGURE 4	8"*	6.00	9.00	18.00	14.24	45.00	8.79	11.75	0.87	8	1.25" SCH.80
	10"*	7.50	10.50	21.00	17.40****	NA	11.63	14.25	1.00	12	NA
	12"*	9.00	12.00	24.00	19.46****	NA	13.69	17.00	1.00	12***	NA

* Gear Operator or Actuation Recommended

** Top (2) holes in each flange are tapped 5/8-11 UNC-2B

*** Top (4) holes in each flange are tapped 7/8-9 UN-2B

**** Dimension to top of stem (No handle)

ASME CLASS 300, FLANGED, STANDARD PORT Dimensions in Inches

	Size	A	B	C	D	E	F	G	H	J	K
FIGURE 1	1/2"	0.81	2.85	5.69	5.85	6.56	2.88	2.62	0.62	4	NA
	3/4"	0.81	3.00	6.00	6.00	6.56	3.03	3.25	0.75	4	NA
	1"	0.81	3.25	6.50	6.03	6.56	3.06	3.50	0.75	4	NA
	1.5"	1.17	3.75	7.50	5.69	6.65	3.47	4.50	0.88	4	NA
	2"	1.50	4.25	8.50	6.63	8.40	4.33	5.00	0.75	8	NA
FIGURE 2	3"	2.25	5.56	11.13	8.55	18.00	5.16	6.63	0.88	8	3/4" SCH.40
	4"	3.00	6.00	12.00	8.68	30.00	5.29	7.88	0.88	8	3/4" SCH.40
FIGURE 3	6"*	4.50	7.94	15.87	13.04	45.00	7.59	10.63	0.88	12	1.25" SCH.80
FIGURE 4	8"*	6.00	9.87	19.75	14.24	45.00	8.79	13.00	1.00	12	1.25" SCH.80
	10"*	7.50	11.19	22.38	17.40***	NA	11.63	15.25	1.13	16	NA
	12"*	9.00	12.75	25.50	19.46***	NA	13.69	17.75	1.25	16**	NA

* Gear Operator or Actuation Recommended

** Top 6 holes in each flange are tapped 1-1/8-8 UN-2B

*** Dimension to top of stem (No handle)

ASME CLASS 600, FLANGED, STANDARD PORT Dimensions in Inches

	Size	A	B	C	D	E	F	G	H	J	K
FIGURE 1	1/2"	0.81	3.63	7.25	5.63	6.65	3.41	2.62	0.62	4	NA
	3/4"	0.81	3.75	7.50	5.87	6.65	3.65	3.25	0.75	4	NA
	1"	0.81	4.25	8.50	5.92	6.65	3.71	3.50	0.75	4	NA
	1.5"	1.17	4.75	9.50	6.21	8.40	3.91	4.50	0.88	4	NA
	2"	1.50	5.75	11.50	7.01	8.40	4.70	5.00	0.75	8	NA
FIGURE 2	3"	2.25	7.00	14.00	8.78	18.00	5.38	6.63	0.88	8	3/4" SCH.40
	4"*	3.00	8.50	17.00	9.08	30.00	5.69	8.50	1.00	8	3/4" SCH.40
FIGURE 3	6"*	4.50	11.00	22.00	13.29	45.00	7.84	11.50	1.12	12	1.25" SCH.80
	8"*	6.00	13.00	26.00	15.24	45.00	9.79	13.75	1.25	12	1.25" SCH.80

* Gear Operator or Actuation Recommended.

ASME CLASS 300, SOCKET WELD, STANDARD PORT

Dimensions

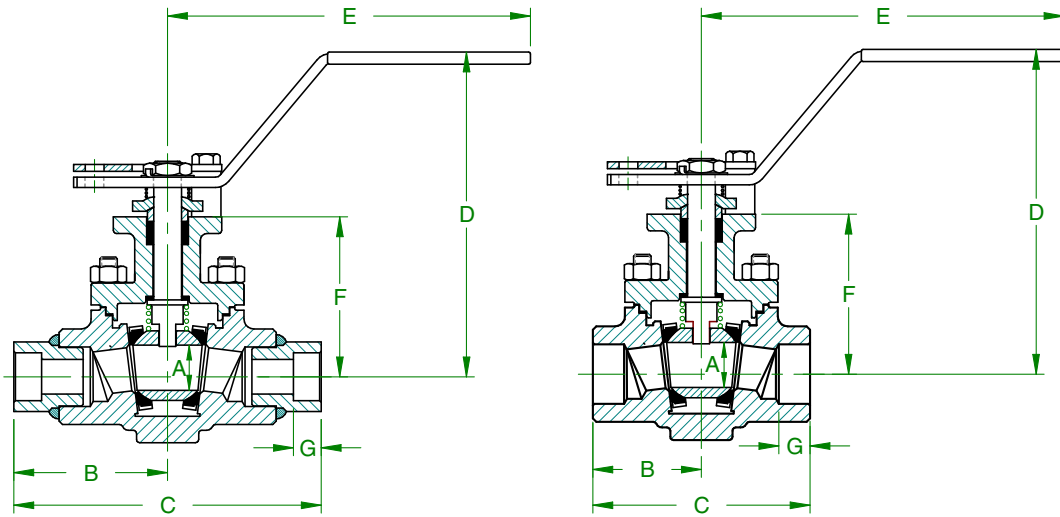

FIGURE 1

FIGURE 2

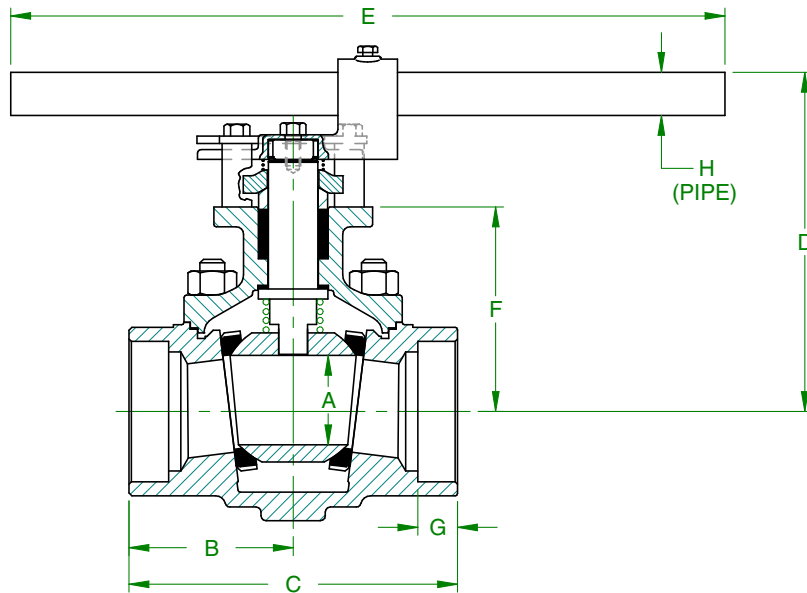

FIGURE 3

ASME CLASS 300, SOCKET WELD, STANDARD PORT Dimensions in Inches

	Size	A	B	C	D	E	F	G	H
FIGURE 1	1/4"	0.81	2.77	5.54	5.84	6.56	2.88	0.50	NA
	1/2"	0.81	2.77	5.54	5.84	6.56	2.88	0.50	NA
	3/4"	0.81	1.96	3.91	5.84	6.56	2.88	0.56	NA
FIGURE 2	1"	0.81	1.96	3.91	5.84	6.56	2.88	0.50	NA
	1.5"	1.17	2.49	4.98	5.57	6.65	3.36	0.55	NA
	2"	1.50	2.86	5.72	6.36	8.40	4.06	0.62	NA
FIG 3	3"	2.25	4.14	8.28	8.55	18.00	5.16	1.00	3/4" SCH.40

ASME CLASS 600, SOCKET WELD, STANDARD PORT

Dimensions

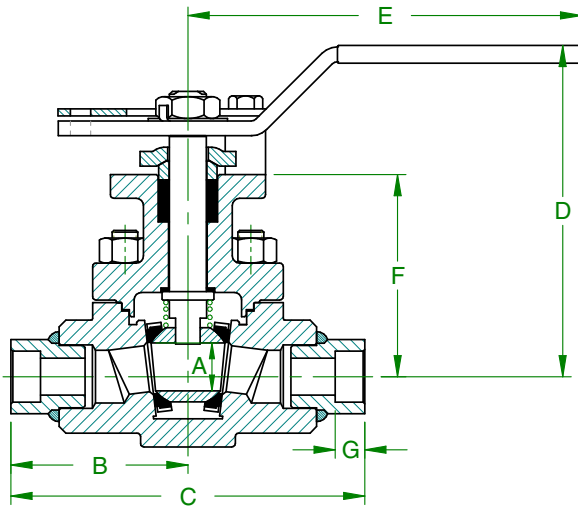

FIGURE 1

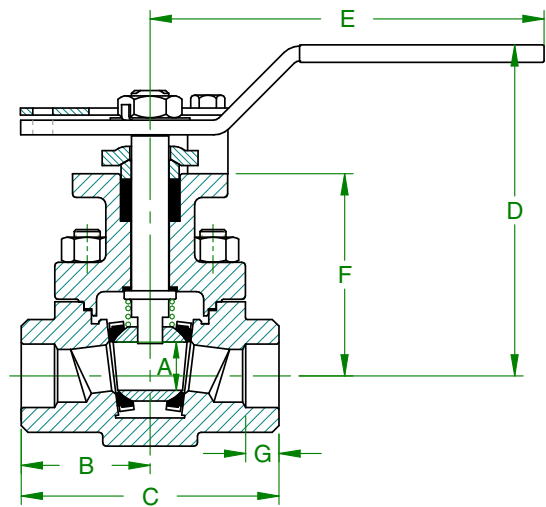

FIGURE 2

ASME CLASS 600, SOCKET WELD, STANDARD PORT Dimensions in Inches

	Size	A	B	C	D	E	F	G
FIGURE 1	1/4"	0.81	2.99	5.98	5.63	6.65	3.41	0.50
	1/2"	0.81	2.99	5.98	5.63	6.65	3.41	0.50
FIGURE 2	3/4"	0.81	2.18	4.35	5.63	6.65	3.41	0.56
	1"	0.81	2.18	4.35	5.63	6.65	3.41	0.50
	1.5"	1.17	2.62	5.23	5.98	8.40	3.68	0.55
	2"	1.50	2.99	5.98	6.57	8.40	4.27	0.62

ASME CLASS 300, NPT, STANDARD PORT

Dimensions

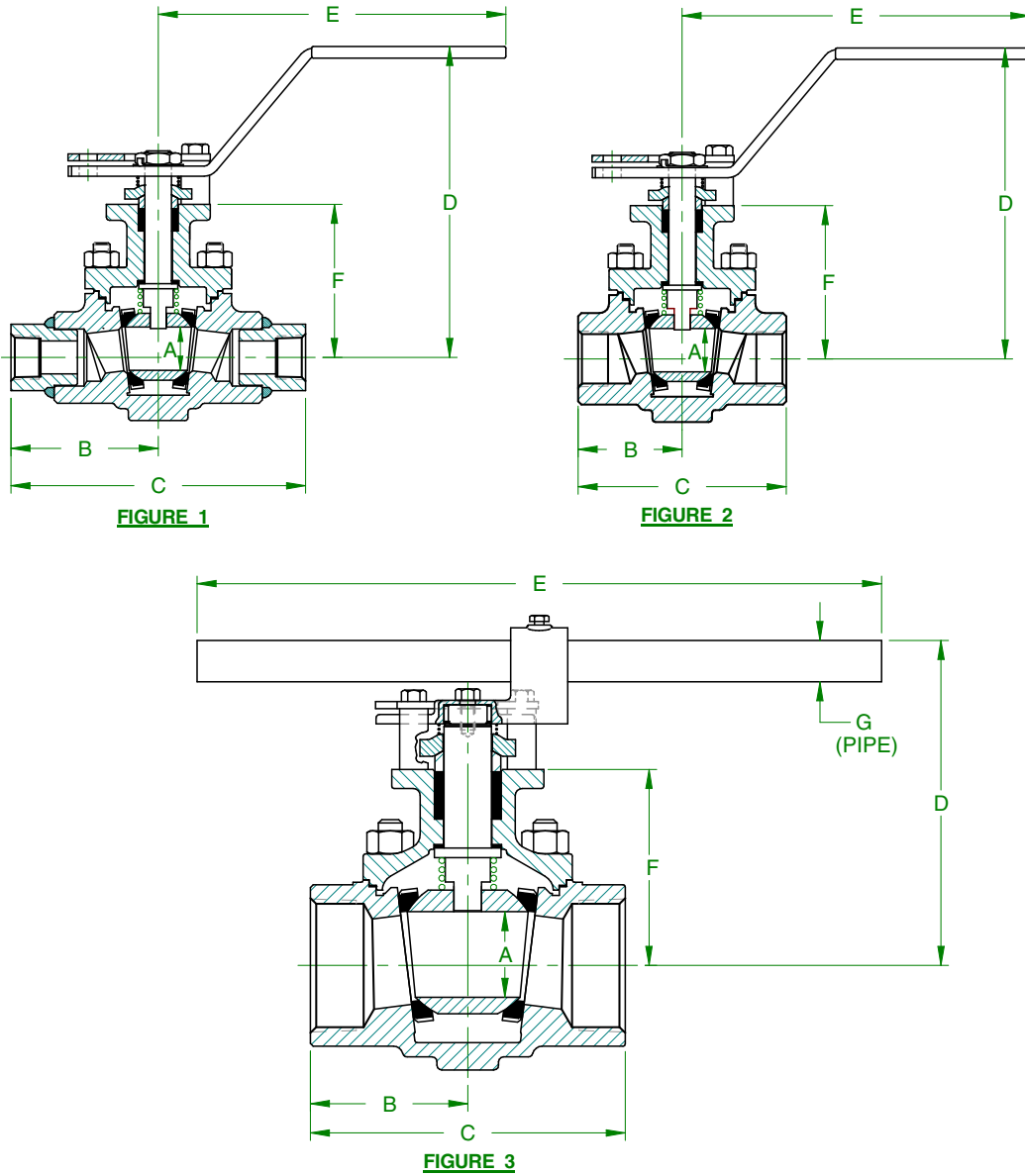

ASME CLASS 300, NPT, STANDARD PORT Dimensions in Inches

	Size	A	B	C	D	E	F	G
FIGURE 1	1/4"	0.81	2.77	5.54	5.84	6.56	2.88	NA
	1/2"	0.81	2.77	5.54	5.84	6.56	2.88	NA
	3/4"	0.81	1.96	3.91	5.84	6.56	2.88	NA
FIGURE 2	1"	0.81	1.96	3.91	5.84	6.56	2.88	NA
	1.5"	1.17	2.49	4.98	5.57	6.65	3.36	NA
	2"	1.50	2.86	5.72	6.36	8.40	4.06	NA
FIG 3	3"	2.25	4.14	8.28	8.55	18.00	5.16	3/4" SCH.40

ASME CLASS 600, NPT, STANDARD PORT

Dimensions

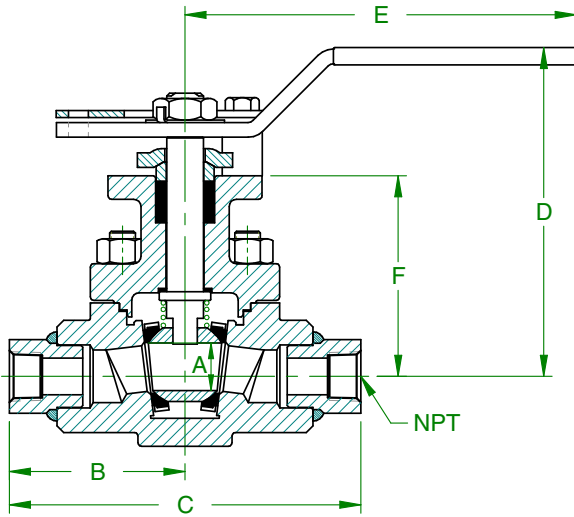

FIGURE 3

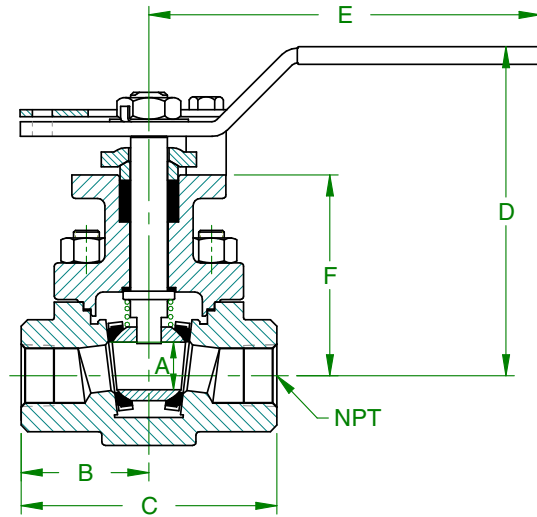

FIGURE 4

ASME CLASS 600, NPT, STANDARD PORT Dimensions in Inches

	Size	A	B	C	D	E	F
FIGURE 3	1/4"	0.81	2.99	5.98	5.63	6.65	3.41
	1/2"	0.81	2.99	5.98	5.63	6.65	3.41
FIGURE 4	3/4"	0.81	2.18	4.35	5.63	6.65	3.41
	1"	0.81	2.18	4.35	5.63	6.65	3.41
	1.5"	1.17	2.62	5.23	5.98	8.40	3.68
	2"	1.50	2.99	5.98	6.57	8.40	4.27

ASME CLASS 300, BUTT WELD, STANDARD PORT

Dimensions

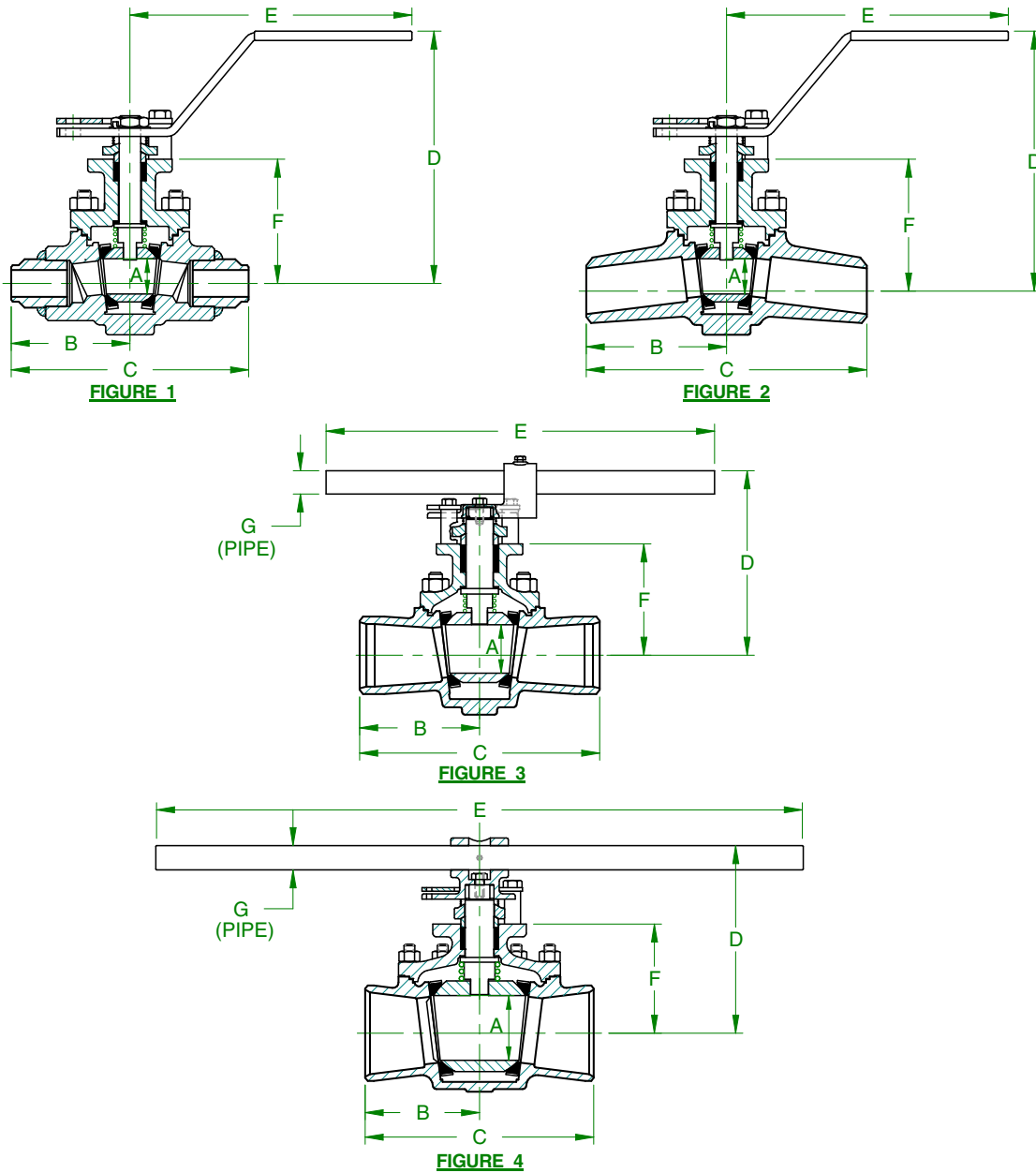

ASME CLASS 300, BUTT WELD, STANDARD PORT Dimensions in Inches

	Size	A	B	C	D	E	F	G
FIG 1	1/2"	0.81	2.75	5.50	5.84	6.56	2.88	NA
	3/4"	0.81	3.00	6.00	5.99	6.56	3.03	NA
FIGURE 2	1"	0.81	3.25	6.50	6.02	6.56	3.06	NA
	1.5"	1.17	3.75	7.50	5.62	6.65	3.40	NA
	2"	1.50	4.25	8.50	6.64	8.40	4.34	NA
FIGURE 3	3"	2.25	5.56	11.12	8.55	18.00	5.16	3/4" SCH.40
	4"	3.00	6.03	12.06	8.68	30.00	5.29	3/4" SCH.80
FIGURE 4	6"	4.50	7.94	15.88	13.04	45.00	7.59	1.25" SCH.80
	8"	6.00	10.25	20.50	14.43	45.00	9.00	1.25" SCH.80

ASME CLASS 600, BUTT WELD, STANDARD PORT

Dimensions

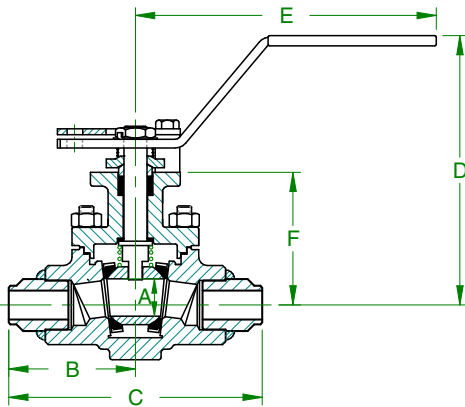

FIGURE 1

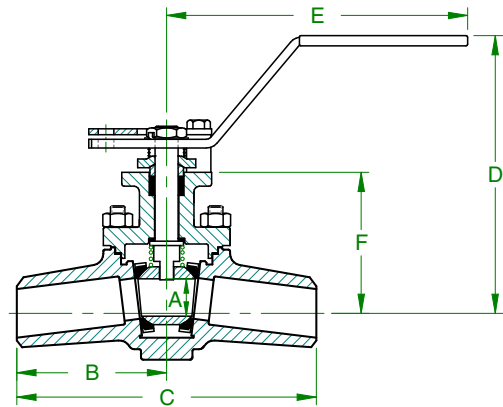

FIGURE 2

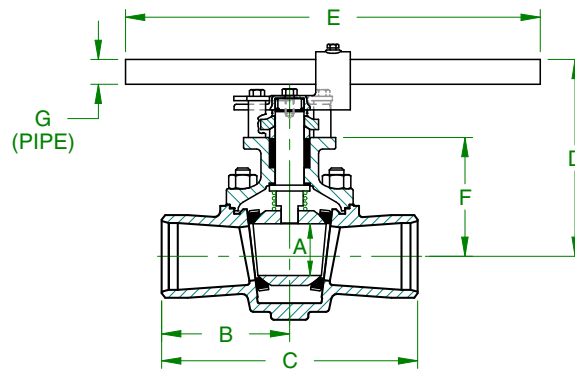

FIGURE 3

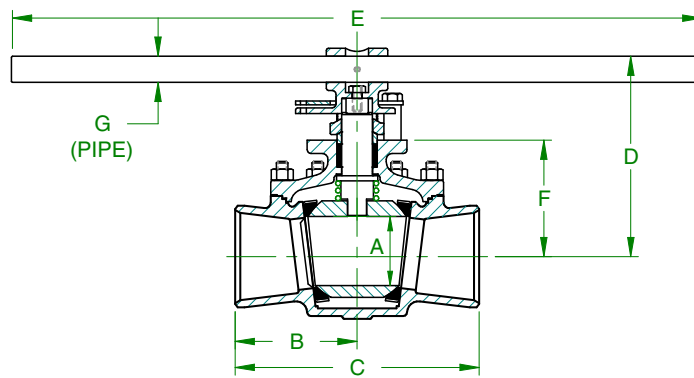

FIGURE 4

ASME CLASS 600, BUTT WELD, STANDARD PORT Dimensions in Inches

	Size	A	B	C	D	E	F	G
FIG 1	1/2"	0.81	3.25	6.50	5.63	6.65	3.41	NA
	3/4"	0.81	3.75	7.50	5.87	6.65	3.66	NA
FIGURE 2	1"	0.81	4.25	8.50	5.93	6.65	3.72	NA
	1.5"	1.17	4.75	9.50	6.22	8.40	3.92	NA
	2"	1.50	5.75	11.50	7.03	8.40	4.73	NA
FIGURE 3	3"	2.25	7.00	14.00	8.78	18.00	5.38	3/4" SCH.40
	4"	3.00	8.50	17.00	9.08	30.00	5.69	3/4" SCH.80
FIG 4	6"	4.50	11.00	22.00	13.29	45.00	7.84	1.25" SCH.80

ASME CLASS, FLANGED, FULL PORT

Dimensions

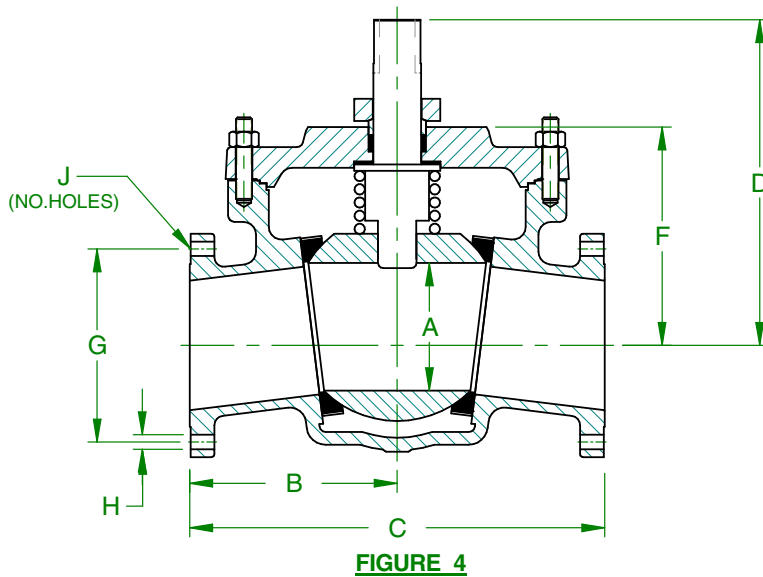
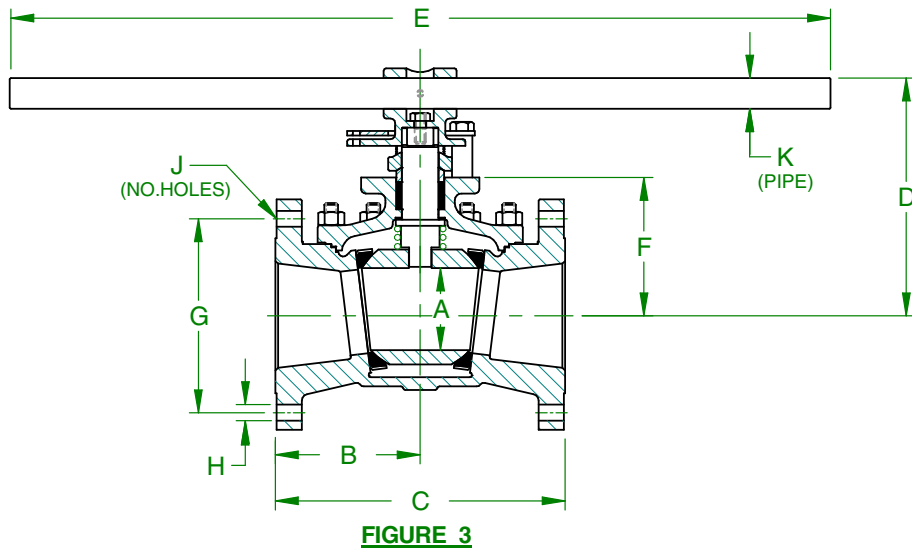
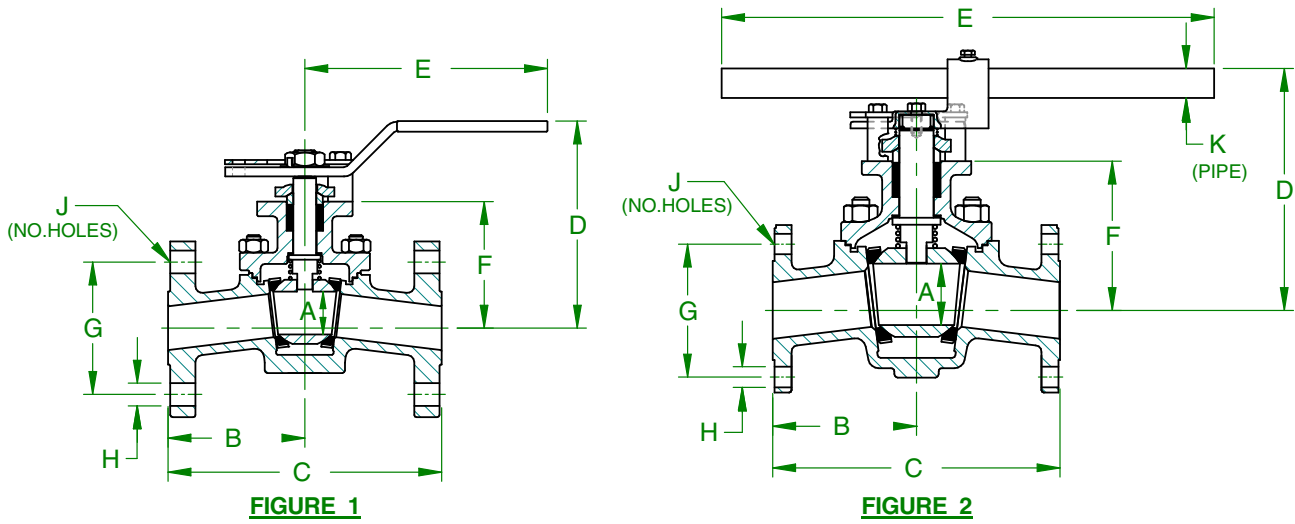

ASME CLASS, FLANGED, FULL PORT

Dimensions

ASME CLASS 150, FLANGED, FULL PORT Dimensions in Inches

	Size	A	B	C	D	E	F	G	H	J	K
FIGURE 1	1"	1.17	3.50	7.00	5.66	6.65	3.44	3.12	0.62	4	NA
	1.5"	1.50	4.37	8.75	6.65	8.40	4.35	3.87	0.62	4	NA
FIGURE 2	2"	2.25	5.25	10.50	8.85	18.00	5.46	4.75	0.75	4	3/4" SCH.40
	3"	3.00	6.75	13.50	9.16	30.00	5.77	6.00	0.75	4	3/4" SCH.40
FIGURE 3	4"	4.50	8.50	17.00	13.46	45.00	8.01	7.50	0.75	8	1.25" SCH.80
	6"*	6.00	10.75	21.50	14.96	45.00	9.51	9.50	0.87	8	1.25" SCH.80
FIGURE 4	8"*	8.00	12.25	24.50	18.72***	NA	12.95	11.75	0.87	8**	NA
	10"*	10.00	16.25	32.50	25.54***	NA	17.14	14.25	1.00	12	NA
	12"*	12.00	19.00	38.00	27.34***	NA	18.94	17.00	1.00	12	NA

* Gear Operator or Actuation Recommended

** Top (2) holes in each flange are tapped 3/4-10 UNC-2B

*** Dimension to top of stem (No handle)

ASME CLASS 300, FLANGED, FULL PORT Dimensions in Inches

	Size	A	B	C	D	E	F	G	H	J	K
FIGURE 1	1"	1.17	3.75	7.50	5.69	6.65	3.47	3.50	0.75	4	NA
	1.5"	1.50	4.75	9.50	6.09	8.40	4.39	4.50	0.88	4	NA
FIGURE 2	2"	2.25	5.56	11.13	8.89	18.00	5.50	5.00	0.75	8	3/4" SCH.40
	3"	3.00	7.62	15.25	9.27	30.00	5.88	6.63	0.88	8	3/4" SCH.40
FIGURE 3	4"	4.50	9.00	18.00	13.52	45.00	8.07	7.88	0.88	8	1.25" SCH.80
	6"*	6.00	11.00	22.00	14.99	45.00	9.54	10.63	0.88	12	1.25" SCH.80
FIGURE 4	8"*	8.00	13.50	27.00	18.87***	NA	13.10	13.00	1.00	12**	NA
	10"*	10.00	16.25	32.50	25.54***	NA	17.14	15.25	1.13	16	NA
	12"*	12.00	19.00	38.00	27.34***	NA	18.94	17.75	1.25	16	NA

* Gear Operator or Actuation Recommended

** Top 2 holes in each flange are tapped 7/8-9 UN-2B

*** Dimension to top of stem (No handle)

ASME CLASS 600, FLANGED, FULL PORT Dimensions in Inches

	Size	A	B	C	D	E	F	G	H	J	K
FIGURE 1	1"	1.17	5.00	10.00	6.25	8.40	3.95	3.50	0.75	4	NA
	1.5"	1.50	6.25	12.50	7.10	8.40	4.79	4.50	0.88	4	NA
FIGURE 2	2"	2.25	6.50	13.00	9.00	18.00	5.61	5.00	0.75	8	3/4" SCH.40
	3"	3.00	8.75	17.50	9.40	30.00	6.01	6.63	0.88	8	3/4" SCH.40
FIGURE 3	4"*	4.50	10.00	20.00	13.64	45.00	8.19	8.50	1.00	8	1.25" SCH.80
	6"*	6.00	13.00	26.00	15.24	45.00	9.79	11.50	1.12	12	1.25" SCH.80
FIG 4	8"*	8.00	15.62	31.25	19.63***	NA	13.86	13.75	1.25	12**	NA

* Gear Operator or Actuation Recommended.

** Top 2 holes in each flange are tapped 1-1/8-8 UN-2B

*** Dimension to top of stem (No handle)

ASME CLASS 300 & 600, SOCKET WELD, FULL PORT

Dimensions

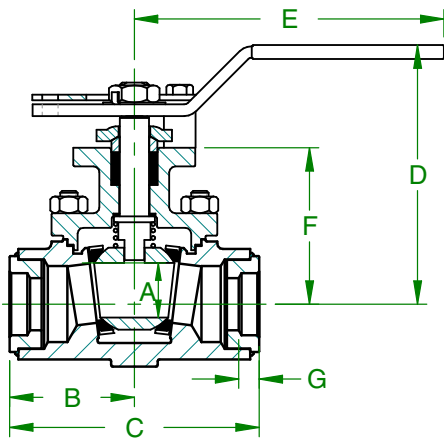

FIGURE 1

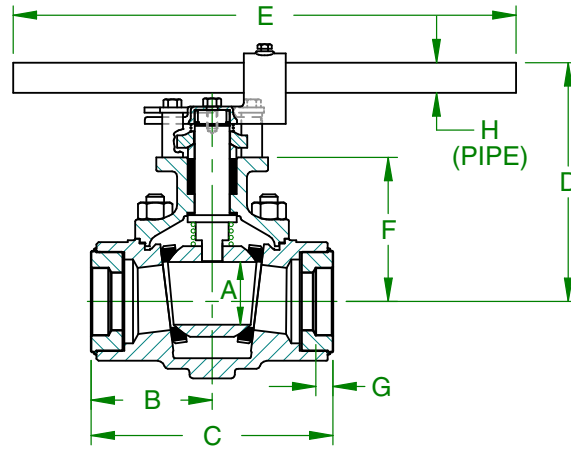

FIGURE 3

ASME CLASS 300, FULL PORT, SOCKET WELD Dimensions in Inches

	Size	A	B	C	D	E	F	G	H
FIGURE 1	1"	1.17	2.68	5.36	5.57	6.65	3.36	0.38	NA
	1.5"	1.50	3.05	6.10	6.36	8.40	4.06	0.55	NA
FIG 3	2"	2.25	4.34	8.67	8.55	18.00	5.16	0.62	3/4" SCH.40

ASME CLASS 600, FULL PORT, SOCKET WELD Dimensions in Inches

	Size	A	B	C	D	E	F	G
FIGURE 1	1"	1.17	2.81	5.61	5.98	8.40	3.68	0.38
	1.5"	1.50	3.18	6.36	6.57	8.40	4.27	0.55

ASME CLASS 300 & 600, NPT, FULL PORT

Dimensions

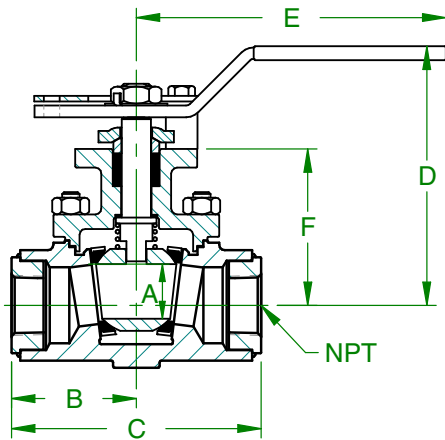

FIGURE 2

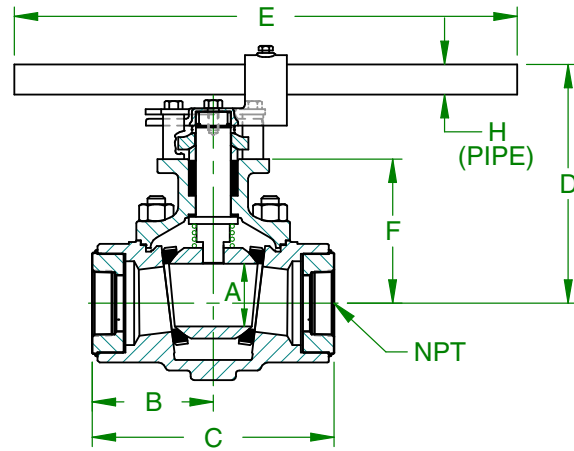

FIGURE 4

ASME CLASS 300, FULL PORT, NPT Dimensions in Inches

	Size	A	B	C	D	E	F	G
FIGURE 2	1"	1.17	2.68	5.36	5.57	6.65	3.36	NA
	1.5"	1.50	3.05	6.10	6.36	8.40	4.06	NA
FIG 4	2"	2.25	4.34	8.67	8.55	18.00	5.16	3/4" SCH.40

ASME CLASS 600, FULL PORT, NPT Dimensions in Inches

	Size	A	B	C	D	E	F
FIGURE 2	1"	1.17	2.81	5.61	5.98	8.40	3.68
	1.5"	1.50	3.18	6.36	6.57	8.40	4.27

CLASS 300, BUTT WELD, FULL PORT

Dimensions

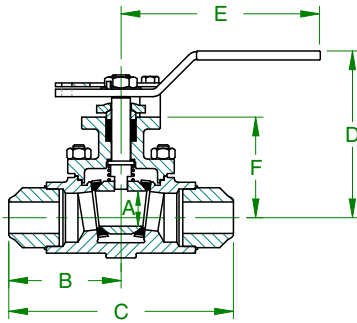

FIGURE 1

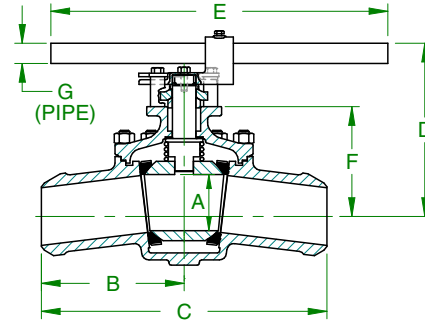

FIGURE 2

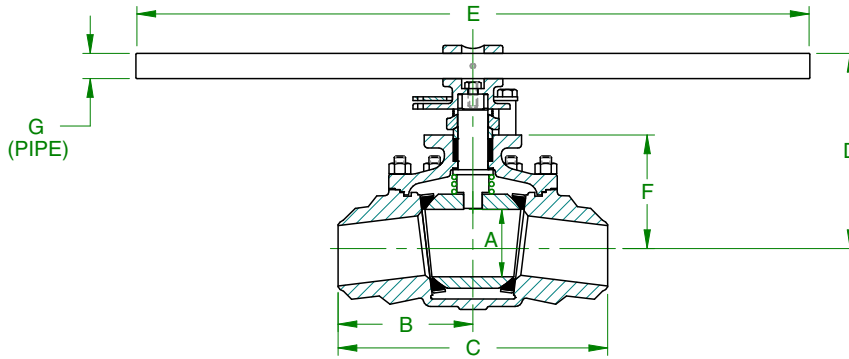

FIGURE 3

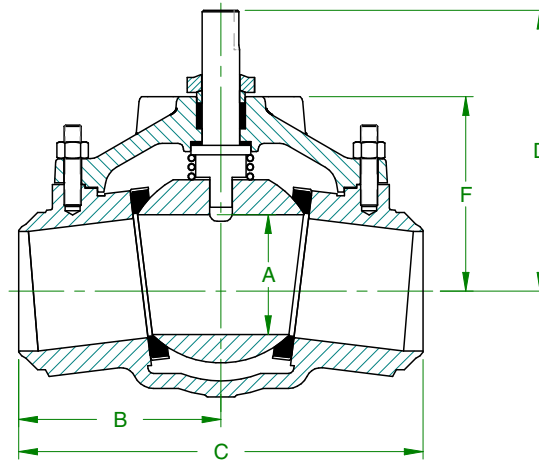

FIGURE 4

ASME CLASS 300, BUTT WELD, FULL PORT Dimensions in Inches

	Size	A	B	C	D	E	F	G
FIGURE 1	1"	1.17	3.75	7.50	5.57	6.65	3.36	NA
	1.5"	1.50	4.75	9.50	6.36	8.40	4.06	NA
FIGURE 2	2"	2.25	5.56	11.13	8.89	18.00	5.50	3/4" SCH.40
	3"	3.00	7.63	15.25	9.27	30.00	5.87	3/4" SCH.40
FIGURE 3	4"	4.50	9.00	18.00	13.52	45.00	8.07	1.25" SCH.80
	6"	6.00	11.00	22.00	14.99	45.00	9.54	1.25" SCH.80
FIGURE 4	8"	8.00	13.50	27.00	18.88*	NA	13.11	NA

*Dimension to top of stem (no handle)

ACTUATION MOUNTING PAD DETAILS

Dimensions

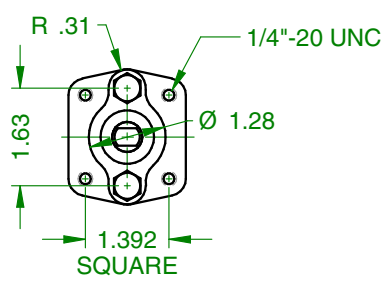

DETAIL A

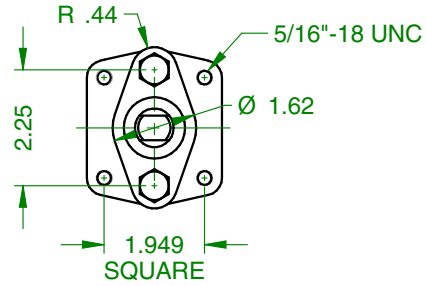

DETAIL B

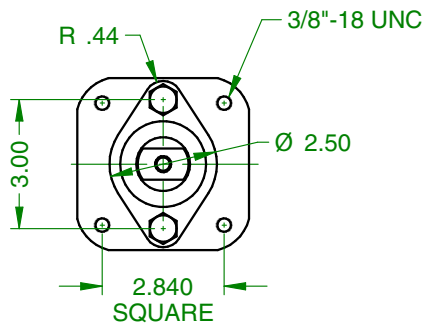

DETAIL C

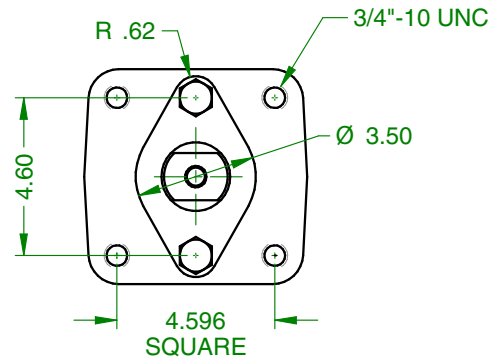

DETAIL D

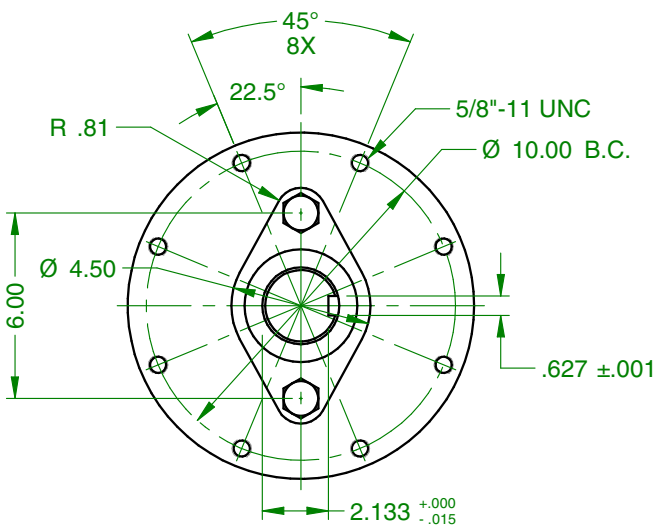

DETAIL E

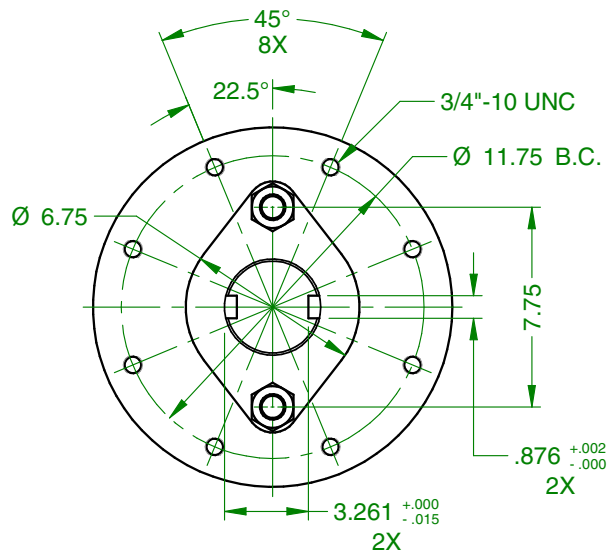

DETAIL F

ACTUATION MOUNTING - FLANGED, STANDARD PORT

Dimensions

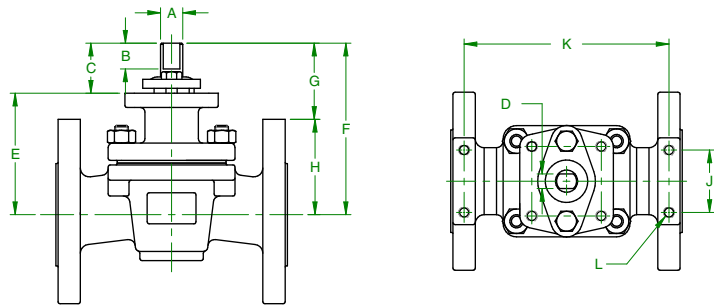

ASME CLASS 150, FLANGED, STANDARD PORT Dimensions in Inches

Size	Mtg Pad	A	B	C	D	E	F	G	H	J	K	L
1/2"	DETAIL A	0.500	0.48	1.00	0.287	2.88	3.88	NA	NA	NA	NA	NA
3/4"						2.94	3.94	1.58	2.36	1.75	4.06	5/16"-18
1"						2.97	3.97	1.29	2.46	1.75	4.43	5/16"-18
1.5"	DETAIL B	0.625	0.72	1.40	0.412	3.41	4.82	2.14	2.68	1.75	5.75	5/16"18
2"						0.750	0.80	1.57	0.477	4.24	5.81	2.51
3"	DETAIL C	1.250	0.50	1.70	0.725	5.16	6.85	2.97	3.88	3.50	7.18	3/8"-16
4"						5.29	6.98	2.35	4.63	4.00	8.19	7/16"-14
6"	DETAIL D	2.000	1.00	2.73	1.375	7.59	10.32	4.70	5.62	4.00	14.25	7/16"-14
8"						8.79	11.52	4.52	7.00	5.00	16.75	1/2"-13
10"	DETAIL E	2.490	2.25*	5.77	NA	11.63	17.40	8.40	9.00	7.00	19.75	3/4"-10
12"						13.69	19.46	NA	NA	NA	NA	NA

*Keyway length

ASME CLASS 300, FLANGED, STANDARD PORT Dimensions in Inches

Size	Mtg Pad	A	B	C	D	E	F	G	H	J	K	L
1/2"	DETAIL A	0.500	0.48	1.00	0.287	2.88	3.88	NA	NA	NA	NA	NA
3/4"						3.03	4.03	1.58	2.45	1.75	5.31	5/16"-18
1"						3.06	4.04	1.48	2.56	1.75	5.75	5/16"-18
1.5"	DETAIL B	0.625	0.72	1.40	0.412	3.47	4.88	1.58	3.30	1.75	6.63	5/16"-18
2"						0.750	0.80	1.57	0.477	4.33	5.90	2.25
3"	DETAIL C	1.250	0.50	1.70	0.725	5.16	6.85	2.60	4.25	3.50	9.88	3/8"-16
4"						5.29	6.98	1.85	5.13	4.00	10.69	7/16"-14
6"	DETAIL D	2.000	1.00	2.73	1.375	7.59	10.32	3.94	6.38	4.00	14.31	7/16"-14
8"						8.79	11.52	3.77	7.75	5.00	18.06	1/2"-13
10"	DETAIL E	2.490	2.25*	5.77	NA	11.63	17.40	8.40	9.00	7.00	20.44	3/4"-10
12"						13.69	19.46	NA	NA	NA	NA	NA

*Keyway length

ASME CLASS 600, FLANGED, STANDARD PORT Dimensions in Inches

Size	Mtg Pad	A	B	C	D	E	F	G	H	J	K	L				
1/2"	DETAIL B	0.625	0.72	1.40	0.412	3.41	4.82	NA	NA	NA	NA	NA				
3/4"						3.65	5.06	2.62	2.44	2.38	6.32	3/8"-16				
1"						3.71	5.11	2.55	2.56	2.38	7.25	3/8"-16				
1.5"						0.750	0.80	1.57	0.477	3.91	5.48	2.23	3.25	2.75	8.06	1/2"-13
2"										4.70	6.27	2.89	3.38	3.50	9.94	1/2"-13
3"	DETAIL C	1.250	0.50	1.70	0.725	5.38	7.08	2.83	4.25	4.75	12.25	1/2"-13				
4"						5.69	7.38	1.88	5.50	5.50	15.00	1/2"-13				
6"	DETAIL D	2.000	1.00	2.73	1.375	7.84	10.57	3.45	7.12	7.00	19.62	3/4"-10				
8"						9.79	12.52	4.15	8.37	7.00	23.13	3/4"-10				

ACTUATION MOUNTING - FLANGED, FULL PORT

Dimensions

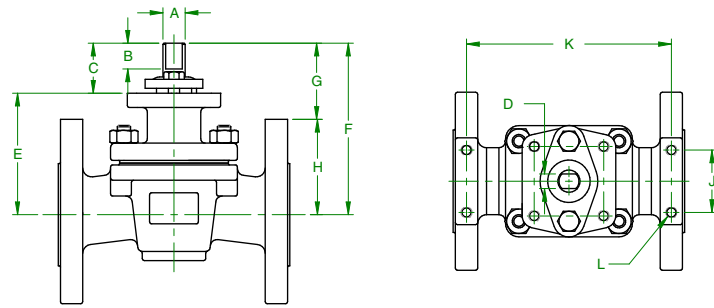

ASME CLASS 150, FLANGED, FULL PORT Dimensions in Inches

Size	Mtg Pad	A	B	C	D	E	F	G	H	J	K	L
1"	DETAIL B	0.625	0.72	1.40	0.412	3.44	4.85	2.47	2.38	1.75	6.44	5/16"-18
1.5"		0.750	0.80	1.57	0.477	4.35	5.92	1.71	2.63	1.75	8.06	5/16"-18
2"	DETAIL C	1.250	0.50	1.70	0.725	5.46	7.16	4.03	3.13	2.25	9.68	5/16"-18
3"						5.77	7.46	3.58	3.88	3.50	12.48	3/8"-16
4"	DETAIL D	2.000	1.00	2.73	1.375	8.01	10.74	5.70	5.04	4.00	15.81	7/16"-14
6"						9.51	12.24	6.08	6.16	4.00	20.25	1/2"-13
8"	DETAIL E	2.490	2.25*	5.77	NA	12.95	26.38	NA	NA	NA	NA	NA
10"	DETAIL F	3.740	3.75*	8.40	NA	17.14	25.56	NA	NA	NA	NA	NA
12"						18.94	25.54	NA	NA	NA	NA	NA

*Keyway length

ASME CLASS 300, FLANGED, FULL PORT Dimensions in Inches

Size	Mtg Pad	A	B	C	D	E	F	G	H	J	K	L
1"	DETAIL B	0.625	0.72	1.40	0.412	3.47	4.88	2.50	2.38	1.75	6.69	5/16"-18
1.5"		0.750	0.80	1.57	0.477	4.39	5.96	1.20	3.19	1.75	8.63	5/16"-18
2"	DETAIL C	1.250	0.50	1.70	0.725	5.50	7.19	3.81	3.38	2.25	9.90	5/16"-18
3"						5.88	7.57	3.23	4.25	3.50	13.68	3/8"-16
4"	DETAIL D	2.000	1.00	2.73	1.375	8.07	10.80	5.67	5.13	4.00	16.50	7/16"-14
6"						9.54	12.27	5.36	6.91	4.00	20.38	1/2"-13
8"	DETAIL E	2.490	2.25*	5.77	NA	13.10	26.38	NA	NA	NA	NA	NA
10"	DETAIL F	3.740	3.75*	8.40	NA	17.14	25.56	NA	NA	NA	NA	NA
12"						18.94	25.54	NA	NA	NA	NA	NA

*Keyway length

ASME CLASS 600, FLANGED, FULL PORT Dimensions in Inches

Size	Mtg Pad	A	B	C	D	E	F	G	H	J	K	L
1"	DETAIL B	0.750	0.80	1.57	0.477	3.95	5.52	2.96	2.56	2.38	8.75	3/8"-16
1.5"						4.79	6.36	3.11	3.25	2.75	11.06	1/2"-13
2"	DETAIL C	1.250	0.50	1.70	0.725	5.61	7.31	3.85	3.46	3.50	11.38	1/2"-13
3"						6.01	7.71	3.46	4.25	4.75	15.56	1/2"-13
4"	DETAIL D	2.000	1.00	2.73	1.375	8.19	10.92	5.42	5.50	5.50	17.75	1/2"-13
6"						9.79	12.52	5.40	7.12	7.00	23.44	3/4"-10
8"	DETAIL E	2.490	2.25*	5.77	NA	13.86	19.63	NA	NA	NA	NA	NA

*Keyway length

ACTUATION MOUNTING - SOCKET WELD & NPT

Dimensions

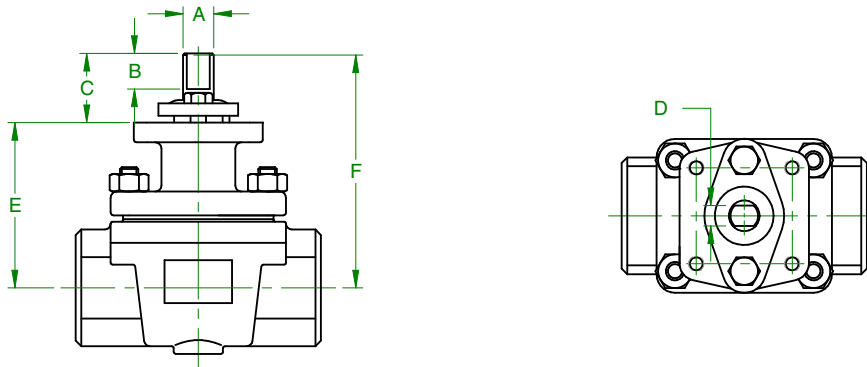

ASME CLASS 300, SOCKET WELD & NPT, STANDARD PORT Dimensions in Inches

Size	Mtg Pad	A	B	C	D	E	F
1/2"	DETAIL A	0.500	0.48	1.00	0.287	2.88	3.88
3/4"						2.88	3.88
1"						3.12	4.12
1.5"	DETAIL B	0.625	0.72	1.40	0.412	3.40	4.80
2"						4.34	5.91
3"	DETAIL C	1.250	0.50	1.70	0.725	5.16	6.86

ASME CLASS 300, SOCKET WELD & NPT, FULL PORT Dimensions in Inches

Size	Mtg Pad	A	B	C	D	E	F
1"	DETAIL B	0.625	0.72	1.40	0.412	3.40	4.80
1.5"						4.34	5.91
2"	DETAIL C	1.250	0.50	1.70	0.725	5.16	6.86

ASME CLASS 600, SOCKET WELD & NPT, STANDARD PORT Dimensions in Inches

Size	Mtg Pad	A	B	C	D	E	F
1/2"	DETAIL B	0.625	0.72	1.40	0.412	3.41	4.82
3/4"							4.82
1"							4.82
1.5"	0.750	0.80	1.57	0.477	3.68	5.25	
2"						4.27	5.84

ASME CLASS 600, SOCKET WELD & NPT, FULL PORT Dimensions in Inches

Size	Mtg Pad	A	B	C	D	E	F
1"	DETAIL B	0.750	0.80	1.57	0.477	3.68	5.25
1.5"						4.27	5.84

ACTUATION MOUNTING - BUTT WELD

Dimensions

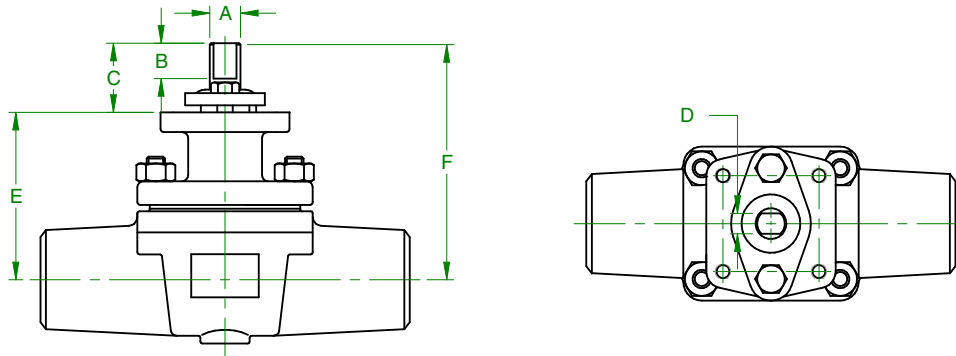

ASME CLASS 300, BUTT WELD, STANDARD PORT Dimensions in Inches

Size	Mtg Pad	A	B	C	D	E	F
1/2"	DETAIL A	0.500	0.48	1.00	0.287	2.88	3.88
3/4"						3.03	3.88
1"						3.06	4.12
1.5"	DETAIL B	0.625	0.72	1.40	0.412	3.40	4.80
2"						4.34	5.91
3"	DETAIL C	1.250	0.50	1.70	0.725	5.16	6.86
4"						5.29	6.99
6"	DETAIL D	2.000	1.00	2.73	1.375	7.59	10.32
8"						9.00	11.71

ASME CLASS 300, BUTT WELD, FULL PORT Dimensions in Inches

Size	Mtg Pad	A	B	C	D	E	F
1"	DETAIL B	0.625	0.72	1.40	0.412	3.36	4.76
1.5"						4.06	5.63
2"	CONTACT FACTORY						
3"	DETAIL C	1.250	0.50	1.70	0.725	5.87	7.57
4"	DETAIL D	2.000	1.00	2.73	1.375	8.07	10.80
6"						9.54	12.27
8"	DETAIL E	2.490	2.25*	5.77	NA	13.11	18.88

*Keyway length

ACTUATION MOUNTING - CLASS 600, BUTT WELD, STANDARD PORT

Dimensions

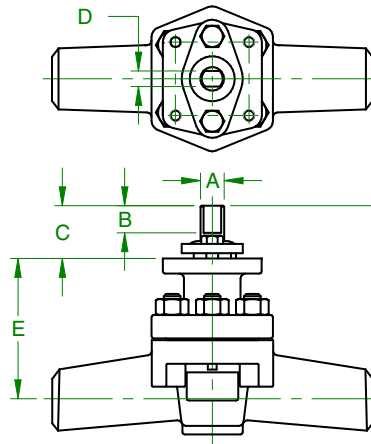

CLASS 600 BUTTWELD STANDARD PORT - SIZES 1/2" THRU 2"

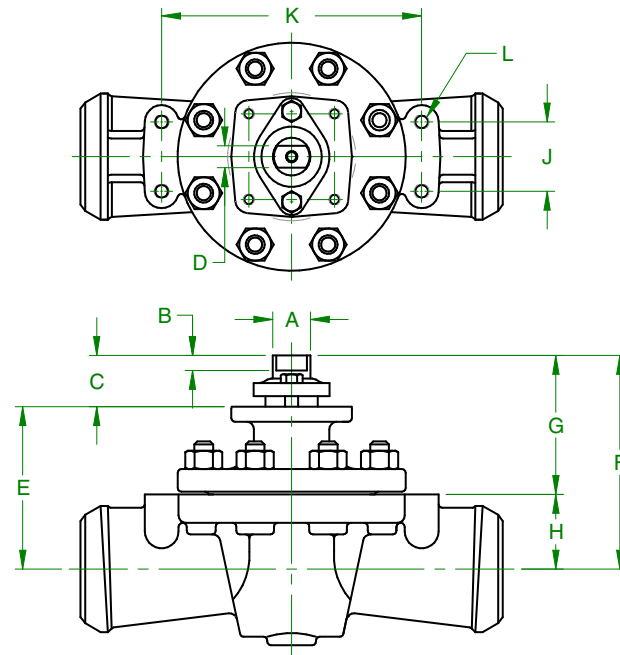

CLASS 600 BUTTWELD STANDARD PORT - SIZES 3" THRU 6"

ASME CLASS 600, BUTT WELD, STANDARD PORT Dimensions in Inches

Size	Mtg Pad	A	B	C	D	E	F	G	H	J	K	L
1/2"	DETAIL B	0.625	0.72	1.40	0.412	3.41	4.82					
3/4"						3.66	5.06					
1"						3.72	5.11					
1.5"						3.92	5.48					
2"						4.73	6.27					
3"	DETAIL C	1.250	0.50	1.70	0.725	5.38	7.08	4.61	2.47	2.42	8.62	1/2"-13
4"						5.69	7.38	4.36	3.02	2.80	11.00	1/2"-13
6"						DETAIL D	2.000	1.00	2.73	1.375	7.84	10.57

STANDARD BONNETS

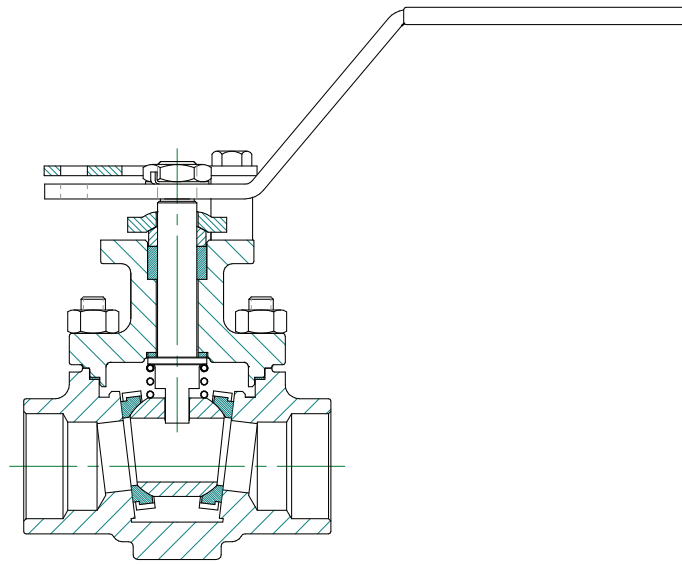

STANDARD BONNET ISO 5211 Mounting Pad

The valve's seat material "code" in the Product Numbering System determines the default stem seal material (default is either PTFE V-Rings or flexible graphite rings).

Note: To meet a wide range of application requirements, a variety of materials are offered. See options in the "How to Specify" section.

PTFE V-RING STEM SEALS

- Extremely low coefficient of friction
- Molded V-shaped rings are "spring-loaded" and self adjusting.
- Provides very good stem seal performance

Enhancement – Live Loaded Packing (add suffix to product number)

"-76" Suffix – Live loaded valve with handle or lever.

"-77" Suffix – Live loaded valve with actuator or manual gear.

Live-loaded, V-ring packing assures long maintenance-free operation by maintaining a constant packing force without over-compression. Corrosion-resistant stainless steel conical washers store compressing energy; consequently, the valve can be cycled more without stem seal adjustments

FLEXIBLE GRAPHITE RING STEM SEALS

- Die Formed Rings

Enhancement – Low Emissions

"EP" Suffix – Cup and cone graphite rings (V-shaped) are often specified for applications where fugitive emissions must be controlled.

Enhancement – Live Loaded Packing

"-76" Suffix – Live loaded valve with handle or lever.

"-77" Suffix – Live loaded valve with actuator or manual gear.

EXTENDED BONNETS

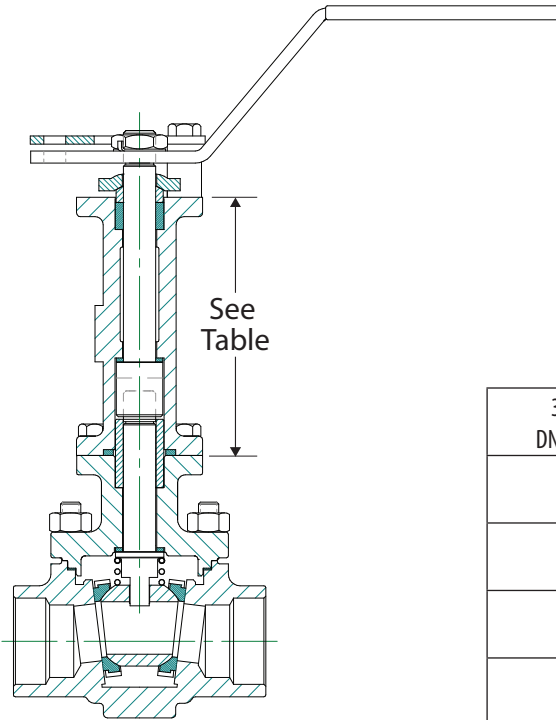

EXTENDED BONNET
(Add "-70" Suffix)

EXTENDED BONNET HEIGHT

	ASME Class 150 ASME Class 300		ASME Class 600	
	Std Port in. (mm)	Full Port in. (mm)	Std Port in. (mm)	Full Port in. (mm)
3" & Smaller DN 80 & Smaller	4" (102)	4" (102)	4" (102)	4" (102)
4" DN 100	4" (102)	6.5" (165)	4" (102)	6.5" (165)
6" DN 150	6.5" (165)	6.5" (165)	6.5" (165)	6.5" (165)
8" DN 200	6.5" (165)	10" (254)	6.5" (165)	10" (254)
10" DN 250	10" (254)	12.5" (318)		
12" DN 300	10" (254)	12.5" (318)		

ADVANTAGES:

- Extended bonnets provide excellent performance in higher temperature or semi cryogenic applications.
 - The extended bonnet design moves the stem seals further away from the process flow's temperature, and the stem seals' temperature is closer to ambient temperature.
- Extended bonnets move the packing adjustment at least 4"; therefore, installed insulation typically will not need to be disturbed to adjust the stem packing.
 - If and when stem leakage occurs, it can be immediately observed and corrective action taken without insulation removal.
- A valuable feature of the Extended Bonnet is that it is field retrofittable.
 - In addition to being able to order valves with several bonnet styles direct from the factory, pre-assembled kits are available with the stem, bonnet, packing, gland, plate and nuts assembled together and properly torqued for dependable performance. Contact your local Apollo Representative for kit part numbers for any specific valve or application.

DOUBLE PACKED BONNETS

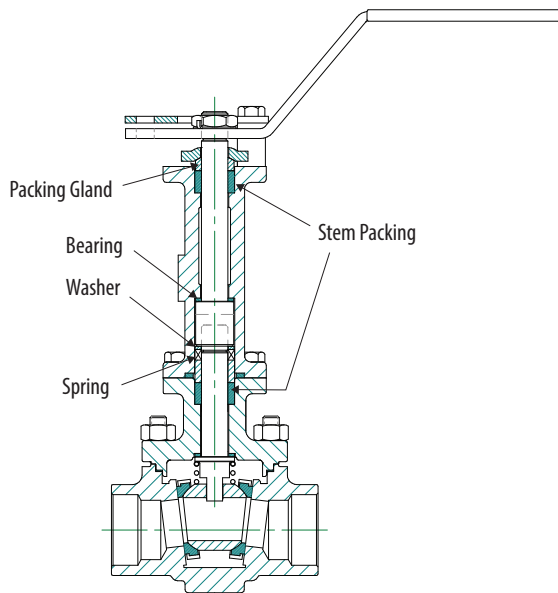

**DOUBLE PACKED
BONNET
(Add “-90” Suffix)**

Apollo recommends also specifying live-loading with the “-90” option.

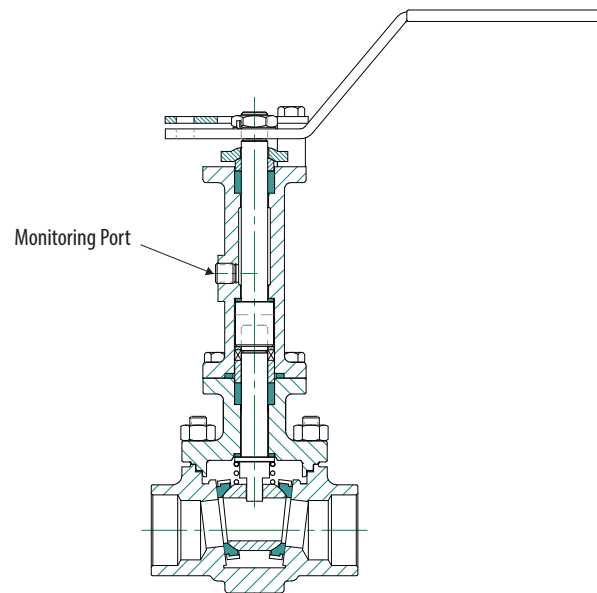

**DOUBLE PACKED
BONNET WITH PORT
(Add “-9P” Suffix)**

Apollo recommends also specifying live-loading with the “-9P” option.

The standard Apollo Top Entry Valve bonnet with PTFE V-Rings or Graphite V-Rings (“-EP”) provide exceptional fugitive emission performance. See *Standard Bonnet Configuration*.

In conditions where double packed shaft sealing systems are required, Apollo also offers the “-90” and “-9P” sealing systems.

Apollo’s Double Packed Bonnets (“-90” and “-9P”):

- Designed and tested to keep fugitive emissions below 100 parts per million volume (ppmv) in your application for tens of thousands of cycles.
- Installs easily on existing valves or can be purchased with new valves.
- Helps seal your process to conserve valuable process fluid while protecting the environment against the emission of hazardous or polluting fluids.
- Longer life and improved reliability of Apollo Double Packed Bonnet systems reduce maintenance cost and downtime.

STEAM JACKETED TOP ENTRY BALL VALVES

Conbraco's Apollo® Top Entry Ball Valves are ideally suited for jacketed applications. The top entry concept allows for continued access to stem packings and valve internals for ease of maintenance without disturbing the jacket itself or removing the valve from the pipeline.

Partial jacketing may be used on standard valves. Partial jacketing is applied just to the center section of the valve and does not incorporate the neck area or flanges of the valve. It is generally specified to allow the use of standard flanges and retain conventional flange bolting.

Welded full jacketing may be applied to valves with oversize flanges or standard flanges. (Fully jacketed, standard flange valves have modified flanges with blind tapped stud holes in place of the ordinary through holes.) Valves and jacketing can be supplied in a variety of materials. Common materials are stainless valves with stainless jackets, but exotic combinations such as Alloy 20 valves with carbon steel flanges and carbon steel jacketing have been supplied to meet the performance and cost requirements for specific applications.

Clamp-on jacketing offers flexibility not available in the other configurations. Clamp-on jacketing can be applied to valves already in service, or can be removed and reinstalled on a replacement valve or another similar valve in another application. Clamp-on jackets can be supplied as a weldment or in cast aluminum. A heat transfer compound can be applied between the clamp-on jacket and valve to improve its efficiency.

Combining these jacketed valves with extended bonnets for safe convenient operation, and adding carbon graphite seats or ceramic balls and seats enables the valve to handle a broad range of viscous materials and temperatures.



Full Welded Jacket

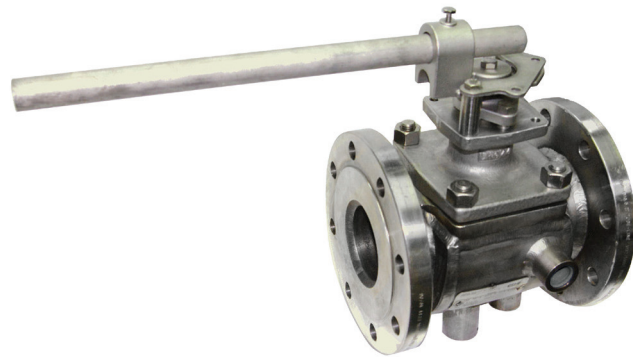

Full Welded Jacket with Oversize Flanges

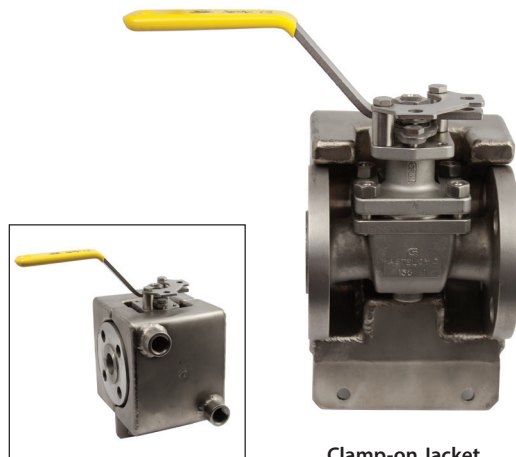

Clamp-on Jacket

SPECIAL APPLICATIONS

“FIRE-SAFE” REQUIREMENTS

Seat and seal arrangements are available to address valves in applications where performance during and immediately after a fire are a concern. “L” (Multiseal) seat configuration offers “tested” fire-safe performance. Graphite spiral wound gaskets are available for bonnet seals. Die-formed Grafoil® in various configurations provide the stem seals.

ABRASIVE & EROSIVE SERVICES

“Soft Seated” valves for abrasive services feature seat inserts completely confined by metallic components. Some designs feature inner and outer seat support rings, where the inner ring helps shield the seat insert from abrasives in the service. Other designs feature one piece seat holders which completely confine the seat insert and provide the same function in protecting the soft seat from abrasive particles in the flow stream.

In addition to the seat configuration options, resilient and rigid seat materials are available. The rigid seat choices include carbon-graphite, ceramic, peek, and carbon reinforced peek. The seats and the ball are both produced from ceramic in the one case. Any of these seats provide improved resistance to abrasion and erosion and additionally extend the potential service range to 1000°F (538°C).

For steam services, the #5 seat, a RPTFE containing 55% bronze and 5% molybdenum disulfide, is an excellent choice as is the #4 carbon-graphite seat.

CHLORINE SERVICE

Valves intended for service in dry chlorine require specific alloy selections, design features, cleaning and testing procedures. In accordance with the guidelines established by “The Chlorine Institute”, Pamphlet 6, Hastelloy trimmed carbon steel valves (model numbers starting with “CH”) are suggested, and M35-1 trimmed carbon steel valves (model numbers beginning “CM”) are the alternative for dry chlorine. All Hastelloy or M35-1 valves are also available.

NOTE: Stainless steel valves or components are not recommended.

Selecting the required “-26” feature insures a valve that has been vented, cleaned, and tested to comply with the requirements of The Chlorine Institute Pamphlet 6.

OXYGEN SERVICE

For this application, cleanliness is of utmost importance. Apollo Top Entry Valves specified for oxygen service (option “-57”) are subjected to rigorous preparation procedures including special pre-cleaning and inspection followed by ultrasonic cleaning and more intense inspection. All to insure that the finished valve is free of burrs and sharp edges as well as cleaned of hydrocarbon residues and particulate matter. Once valves destined for oxygen service enter Conbraco’s clean room for preparation, they do not leave until they have been cleaned, assembled, thoroughly tested, inspected, tagged and bagged to meet customer requirements.

All Apollo Top Entry Valves have “anti-static” features designed in. Valves for oxygen service must also be fitted with PTFE and packing. When planning to insulate valves, consider specifying one of our extended bonnet options.

HIGH TEMPERATURE SERVICE

For any applications utilizing graphite, carbon graphite, peek, carbon reinforced peek, or ceramic seats, a ball stop should be incorporated into the valve design (option “RS”). This option is suggested at any temperature but it becomes a necessity above 500°F (260°C) or when using ceramic seats. The ball stop prevents the ball and seat from sliding down the 7° wedge when expansion caused by the temperature increase widens the wedge. If the ball was permitted to slide down the wedge, the valve would be locked tight when cooling caused the wedge to contract.

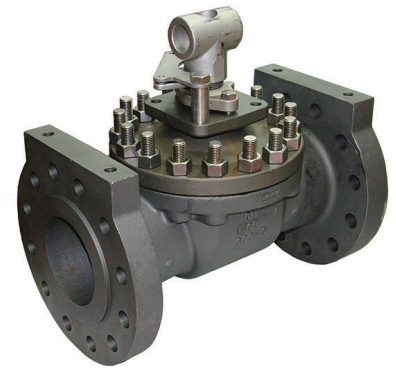

FLOW COEFFICIENTS

FLOW OF LIQUIDS

$$Q = C_v \sqrt{\frac{P_D}{S_G}} \quad \text{or} \quad P_D = \frac{Q^2 (S_G)}{(C_v)^2}$$

Where: Q = Flow in US GPM
 PD = Pressure Drop (PSI)
 SG = Specific Gravity at flow conditions
 CV = Valve Flow Coefficient

FLOW OF GASES

$$P_D = \frac{5.4 (10^{-7}) Q^2 (T) (S_G)}{[(C_v)^2 (P_2)]}$$

$$Q = 1360 (C_v) \sqrt{\frac{[(P_D) (P_2)]}{[S_G (T)]}}$$

Where: Q = Flow in SCFM
 PD = Pressure Drop (PSI)
 P2 = Outlet Pressure PSIA
 T = Temp.(°R) or (°F + 460)
 SG = Specific Gravity at flow conditions
 CV = Valve Flow Coefficient

The table below presents the Flow Coefficients (Cv) for Apollo® Top Entry Ball Valves. This number represents the flow (in gallons per minute of water) required to produce a 1 psig pressure drop across the valve. The data shown is for a valve in the full open position. Data for various degrees of open are available upon request. The values shown represent the average for several tests which highlighted the variability of Flow Coefficients. It is not unreasonable to expect a 10% to 20% deviation for a specific valve from the nominal figures shown.

Knowing specific system characteristics; such as line size, flow rate, temperature and pressure and knowing specific fluid characteristics; such as specific gravity, density, or compressibility factor allows the verification of the pressure drop across a known valve. Or conversely, in the absence of a valve size and knowing an acceptable pressure drop under the described flow conditions, it is possible to select an appropriately sized valve.

APOLLO® TOP ENTRY FULL PORT VALVE FLOW COEFFICIENTS

Valve Size	150 Class Flanged	300 Class Flanged	600 Class Flanged
1"	95	90	85
1-1/2"	230	225	200
2"	435	420	400
3"	1050	1000	950
4"	1950	1900	1800
6"	4800	4300	4300
8"	9100	8700	8000

APOLLO® TOP ENTRY VALVE FLOW COEFFICIENTS

Valve Size	150 Class Flanged End	300 Class Flanged End	300 Class Butt weld End	300 Class Socket Weld	300 Class NPT	600 Class Flanged End	600 Class Butt weld End	600 Class Socket Weld	600 Class NPT
1/2"				20	20			20	20
3/4"	50	50	50	30	30	50	50	30	30
1"	60	60	60	40	40	60	60	40	40
1-1/2"	100	100	100	70	70	100	100	70	70
2"	180	180	180	120	120	190	190	120	120
3"	330	400	400	260	260	410	410	260	260
4"	600	720	720				780	780	
6"	1,500	1,500	1,500				1,700	1,700	
8"	2,500	2,500					3,100		
10"	3,800	3,800					4,900		

OPERATING TORQUE

There are several elements involved in developing an appropriate "in-service" valve operating torque. Selection of the basic valve torque constant, shown on this page establishes the nominal valve torque based on the valve size, specified valve seat and the approximate working pressure.

Armed with the nominal valve operating torque, adjustments are now made to account for individual service conditions. These factors are selected from the table at the lower right. They are additive, or combined in series and used to arrive at the "in-service" torque.

EXAMPLE

Selected Valve:
3" 150 w/"M" seat
(Model: CS-BM0-01)

Torque Constant:
1250 in-lbs

Service Factors:
ON/OFF Service 0.0
Clean Dry Air 0.3
Weekly Operation 0.2
Net Service Factor 0.5

"In Service" Valve Torque:
 $1250 \times (1 + 0.5) = 1875$ in-lbs
(This is the valve torque used to select an actuator.)

TORQUE CONSTANTS FOR TOP ENTRY BALL VALVES

Seats	Valve Size Std. Port (Inches)	Valve Size Full Port (Inches)	Differential Pressures (psig)					(In.-Lbs.)	
			100	285	500	740	1480	LSST*	Grafoil® Adder
5	1/2 thru 1	1/2 thru 3/4	85	110	140	180	290	170	68
6**	1-1/2	1	205	260	330	415	660	410	96
C	2	1-1/2	350	430	550	735	1,200	700	127
D	3	2	950	1,250	1,650	2,000	3,200	1,900	245
G	4	3	2,000	2,500	3,300	4,100	6,500	4,000	399
J	6 ^{††}	4 ^{††}	5,300	6,700	8,200	11,400	18,000	10,600	661
L	8 ^{††}	6 ^{††}	11,000	14,000	18,500	25,000	36,000	22,000	900
M	10 ^{††}	8 ^{††}	18,500	22,000	30,000	40,000	62,000	37,000	1,326
U**									
4	1/2 thru 1	1/2 thru 3/4	115	160	210	260	450	230	68
	1-1/2	1	270	370	480	590	1,000	540	96
8	2	1-1/2	475	650	860	1,050	1,750	950	127
9	3	2	1,250	1,850	2,400	2,950	4,900	2,500	245
B	4 ^{††}	3 ^{††}	2,700	3,700	4,900	5,900	10,000	5,400	399
H	6 ^{††}	4 ^{††}	7,410	10,100	13,400	16,400	25,300	14,800	661
N	8 ^{††}	6 ^{††}	15,000	20,000	26,000	34,500	56,000	30,000	900
	10 ^{††}	8 ^{††}	25,000	32,000	45,000	60,000	96,000	50,000	1,326

*LSST - Long Stand Still Torque

**Rated torque for #6 and U seat add 30%

†Rated torque for #9 ceramic seat is to be increased by 10%

††Gear operator or actuation recommended

BALL VALVE TORQUE ADJUSTMENT FACTORS

PROVISION	CONDITION	FACTOR
Type of Operation	On/Off Service	0
	Modulating Service	0.25
Process Media	Liquid, Clean Particle Free	0
	Liquid, Dirty, Slurry, Raw Water	0.3 to 0.8
	Liquid, Black Liquor, Lime Slurry	0.8
	Liquid, Oil, Lubricating	0
	Liquid, Viscous, Molasses	0.3
	Gas, Clean & Wet	0
	Gas, Dry	0.3 to 0.5
	Gas, Dirty, Air Slurry, Natural Gas	0.5 to 1
	Oxygen, Chlorine	0.5
	Superheated Steam, Saturated Steam	Refer to Process Temp.
Frequency of Operation**	Once Per Day or More	0
	Once Per Week	0.2
	Once Per Month	0.5
	Less Than Once Per Month (LSST)	1
Process Temperature	Applications Above 225 Deg F (107°C)	0.50
	Applications Below -20 Deg F (-29°C)	0.25
Option "-49"	Assembled Dry	0.3
Option "-57"	Oxygen Cleaned	0.3
Option "-67"	Cleaned for Industrial Gas	0.3
Option "-90"	Double Packed Extended Bonnet	0.2
Customer Specified	Prescribed Safety Factor	0.2 to 2

** If accounting for LSST disregard frequency of operation.

HOW TO SPECIFY TOP ENTRY BALL VALVES

C	S	J	L
BODY MATERIAL	TRIM MATERIAL	CLASS, PORT, ENDS	SEAT
<p>CARBON STEEL CASTING C - ASTM A216 Grade WCB</p> <p>L - A352 LCC <i>low-temp service</i></p> <p>P - A217 C12 <i>chromium-molybdenum high temp service</i></p> <p>STAINLESS STEEL CASTING S - ASTM A351 Grade CF8M (316 SS)</p> <p>A - A351 CN7M (Alloy 20)</p> <p>B - A351 CF3M* (316L)</p> <p>G - A351 CG8M (317 SS)</p> <p>J - A995 CD3MN (2205 duplex)</p> <p>K - A995 CD3MWCuN (2507 super duplex)</p> <p>R - A351 CN3MN (AL6XN® super austenitic)</p> <p>W - A351 CK3MCuN (254 SMO)</p> <p>NICKEL BASED ALLOY CASTING F - ASTM A494 Grade CW6MC (INCONEL™ 625)</p> <p>H - A494 CW12MW (Hastelloy® C)</p> <p>M - A494 M35-1 (MONEL®)</p> <p>N - A494 CZ100 <i>Commercially pure nickel</i></p> <p>Y - A494 N12MV (Hastelloy® B-2)</p> <p>TITANIUM CASTING T - ASTM B367 Gr C3 <i>Commercially pure titanium</i></p>	<p>STAINLESS STEEL S - 316 SS</p> <p>A - Alloy 20</p> <p>B - 316L SS</p> <p>E - 410 SS</p> <p>J - 220S Duplex SS</p> <p>K - 2507 Super Duplex SS</p> <p>R - AL6XN</p> <p>W - 254 SMO</p> <p>NICKEL BASED F - Inconel</p> <p>H - Hastelloy C</p> <p>M - M35-1 (Monel)</p> <p>D - Hastelloy C Stem, M35-1 Ball</p> <p>N - Nickel</p> <p>Y - Hastelloy</p> <p>TITANIUM T - Titanium</p>	<p>CLASS 150 <i>Standard Port</i> B - Flanged <i>Full Port</i> E - Flanged</p> <p>CLASS 300 <i>Standard Port</i> C - Flanged D - NPT G - NPT x Socket Weld N - Socket Weld P - Buttweld R - FLG x Buttweld S - RTJ Flanges <i>Full Port</i> 3 - Buttweld F - Flanged L - NPT M - Socket Weld Y - NPT x Socket Weld</p> <p>CLASS 600 <i>Standard Port</i> H - NPT J - Socket Weld K - Flanged Q - NPT x Socket Weld W - Buttweld <i>Full Port</i> 4 - NPT 6 - NPT x Socket Weld 7 - Buttweld T - Socket Weld U - Flanged</p>	<p>MULTI-SEAL L - Multi-Seal TFM, API-607 Certified (Figure 3) M - Multi-Seal (Figure 1)</p> <p>UHMWPE 6 - UHMWPE (Figure 2) U - UHMWPE (Figure 1)</p> <p>GRAPHITE ("HARD" SEAT TIGHTNESS) 4 - Carbon Graphite, 750°F max. (Figure 1) H - High Temp Graphite, 1000°F max. (Figure 1)</p> <p>PEEK ("HARD" SEAT TIGHTNESS) 8 - PEEK (Figure 2) B - PEEK, 30% Carbon Reinforced (Figure 2)</p> <p>CERAMIC ("HARD" SEAT TIGHTNESS) 9 - Ceramic (Figure 4)</p> <p>NYLON N - Nylon</p> <p><i>Additional Seats</i> 5 - 55% Bronze, 5% Moly, (Figure 2) C - PFA (Figure 2) D - SRPTE, 60% SS, 40% TFE by weight 50% SS Min (Figure 2) G - PCTFE (Figure 1) J - PFA, API-607 Certified (Figure 3)</p>

* Flanged Valves Only - CF3M
() Represents Close
Wrought Equivalent

Figure Numbers in parentheses indicate the Seat Design. See "Seat Data" section for details.

Seat code also dictates default seal material and default suffix. See "Materials" section for details.

Pressure-Temperature ratings are found in the "Pressure-Temperature Ratings" section.

HOW TO SPECIFY TOP ENTRY BALL VALVES

4 SIZE (IN)	24 OPTIONS	
3 - 1/2" 4 - 3/4" 5 - 1" 7 - 1.5" 8 - 2" 0 - 3" A - 4" C - 6" E - 8" G - 10" H - 12"	<ul style="list-style-type: none"> -01 Default Suffix for "M" and "G" Seats -24- Default Suffix for 4, 5, 6, 8, 9, B, C, D, H, J, L, N, U Seats <hr/> <p><i>Optional Features may be used alone or in combination (simply add the suffixes to the Product Number in the order listed below).</i> <i>Note: The "-01" suffix is not used if there are additional suffixes.</i> <i>Note: Not all combinations are available on all valves.</i></p> <hr/> <ul style="list-style-type: none"> -04- 2.25" Stem Extension -10- Stainless Pipe Handle (3" & Larger Carbon Steel only) -14- Vented Body Design -15- Wheel Handle, Stainless Steel -24- Graphite Packing & Spiral Wound Graphite Gasket -- Not always Fire Safe -26- Vented & Cleaned for Chlorine Service (CS, HC, & MO only) -45- No Lever or Nut -- Bare Stem -49- Assembled Dry -- No Lubrication -57- Oxygen Cleaned -67- Cleaned for Industrial Gases -70- Extended Bonnet -73- TFE Packing, Spiral Wound Seals - TFE Fillers -76- Live Loaded - Valve with Lever -77- Live Loaded - Valve with Gear or Actuator -82- Flat Faced Flanges -90- Double Packed Extended Bonnet -9P- Double Packed Extended Bonnet with Port -BB- Titanium & Graphite Spiral Wound Bonnet Gasket -BC- ASTM A193 Grade B7 Bolts -BT- Teflon Coated ASTM A193 Grade B7 Fasteners -CB- Ceramic Ball Only -CS- Ceramic Seat Only -DF- Delta Ferrite Report (SS Only) -DP- Dye Penetrant -EP- V-Ring Graphite Packing -KB- Kolsterised Ball -MG- Manual Gear Operator -MH- Manual Gear Operator with Lockout -MJ- Manual Gear Operator with Oversize handwheel -MK- Manual Gear Operator with Lockout & Lockout -MP- Positive Material Identification -NC- NACE Certified (Rc 22 Max) -NO- Titanium Bolts -PG- No Plastisol Grip on Lever (used in Tobacco plants) -RS- Blow-Out Proof Welded Ball Stop with Safety Cap -SR- Spring return -TC- Hydrostatic Test with Certified Report -TD- Test to API 6D with Certification -TM- Material Traceability -TR- Hydrostatic Test with certification & MTR -TW- Hydrostatic Test with Witness & Certification <p>Butt Weld } Butt Weld valves include a suffix that specifies the end preparation Weld } e.g. schedule W1(SCH10), W4(SCH40), W8(SCH80), etc...</p>	MODEL REVISION Assigned by Factory

EXAMPLE:
CSJL424A

Carbon Steel Body
 316 SS Trim
 Class 600
 Standard Port
 Socket Weld Ends
 API-607, Multiseal Seat
 3/4"
 Spiral Wound Flexible
 Graphite Gasket
 Flexible Graphite Packing
 Model Revision = A

NOTE: This is a very limited list of the available options. Contact the factory for specific requirements and availability.

* MG is Generic for Gear Operators. Contact Factory or Price Book for Specific Application and Part No.

HOW TO SPECIFY SEAL REPAIR KIT FOR ISO 5211 BONNET

PLEASE USE ALL DIGITS WHEN ORDERING

S	S	O	M	5	O1	A
TOP ENTRY REPAIR KIT	TRIM MATERIAL	VALVE CLASS	SEAT	SIZE	ADDITIONAL FEATURES	MODEL REVISION
Use "S" for 1st Character	Insert trim codes from "How to Specify" table	0 - 150/300 1 - 600	Insert seat codes from "How to Specify" table <i>Repair kits with HARD seats also include the ball. The ball is lapped to the seats.</i>	5 - 1/2" - 1" 7 - 1-1/2" 8 - 2" 0 - 3" A - 4" C - 6" E - 8" G - 10" H - 12"	Examples: 01 - Standard (PTFE Packing, RPTFE Body Seal) 24 - Graphite Packing, Spiral Wound Body Seal <i>There may be cases where multiple options are used: EX: -90EP, -24RS, -90EPRS</i>	A - ISO Bonnet Configuration

STANDARD MATERIAL LIST BY SEAT SELECTION

Seat Designation	Stem Packing	Bonnet Gasket	Stem Bearing	Class	Default Suffix
4	Flexible Graphite	Spiral Wound Graphite	Nitronic 60	All	24
5	Flexible Graphite	Spiral Wound Graphite	PEEK	All	24
6	Flexible Graphite	Spiral Wound Graphite	PEEK	All	24
8	Flexible Graphite	Spiral Wound Graphite	PEEK	All	24
9	Flexible Graphite	Spiral Wound Graphite	Nitronic 60	All	24
B	Flexible Graphite	Spiral Wound Graphite	PEEK	All	24
C	Flexible Graphite	Spiral Wound Graphite	PEEK	All	24
D	Flexible Graphite	Spiral Wound Graphite	PEEK	All	24
G	PTFE	RPTFE	PEEK	150/300	01
		Spiral Wound PTFE	PEEK	600	
H	Flexible Graphite	Spiral Wound Graphite	Nitronic 60	All	24
J	Flexible Graphite	Spiral Wound Graphite	PEEK	All	24
L	Flexible Graphite	Spiral Wound Graphite	PEEK	All	24
M	PTFE	RPTFE	PEEK	150/300	01
		Spiral Wound PTFE	PEEK	600	
N	Flexible Graphite	Spiral Wound Graphite	Nylon	All	24
U	Flexible Graphite	Spiral Wound Graphite	PEEK	All	24

WARRANTY AND LIMITATIONS OF LIABILITY



Conbraco Industries, Inc. warrants, to its initial purchaser only, that its products which are delivered to this initial purchaser will be of the kind described in the order or price list and will be free of defects in workmanship or material for a period of FIVE years from the date of delivery to you, our initial purchaser. This warranty applies to Apollo brand product with "Made in the USA" markings only.

Should any failure to conform to this warranty appear within FIVE years after the date of the initial delivery to our initial purchaser, Conbraco will, upon written notification thereof and substantiation that the goods have been stored, installed, maintained and operated in accordance with Conbraco's recommendations and standard industry practice, correct such defects by suitable repair or replacement at Conbraco's own expense.

APOLLO INTERNATIONAL PRODUCTS: Conbraco Industries, Inc. warrants its International products, to its initial purchaser only, that its international products which are delivered to this initial purchaser will be of the kind described in the order or price list and will be free of defects in workmanship or material for a period of TWO years from the date of delivery to you, our initial purchaser.

THIS WARRANTY IS EXCLUSIVE AND IS IN LIEU OF ANY IMPLIED WARRANTY OF MERCHANTABILITY, FITNESS FOR A PARTICULAR PURPOSE OR OTHER WARRANTY OF QUALITY, WHETHER EXPRESSED OR IMPLIED, EXCEPT THE WARRANTY OF TITLE AND AGAINST PATENT INFRINGEMENT. Correction of non-conformities, in the manner and for the period of time provided above, shall constitute fulfillment of all liabilities of Conbraco to our initial purchaser, with respect to the goods, whether based on contract, negligence, strict tort or otherwise. It is the intention of Conbraco Industries, Inc. that no warranty of any kind, whether expressed or implied shall pass through our initial purchaser to any other person or corporation.

LIMITATION OF LIABILITY: Conbraco Industries, inc. SHALL NOT UNDER ANY CIRCUMSTANCES BE LIABLE FOR SPECIAL OR CONSEQUENTIAL DAMAGES SUCH AS, BUT NOT LIMITED TO, DAMAGES OR TO LOSS OF OTHER PROPERTY OR EQUIPMENT, LOSS OF PROFITS OR REVENUE, COST OF CAPITAL, COST OF PURCHASED OR REPLACEMENT GOODS, OR CLAIMS OF CUSTOMERS OF OUR INITIAL PURCHASER. THE REMEDIES OF OUR INITIAL PURCHASER, AND ALL OTHERS, SET FORTH HEREIN, ARE EXCLUSIVE, AND THE LIABILITY OF CONBRACO WITH RESPECT TO SAME SHALL NOT, EXCEPT AS EXPRESSLY PROVIDED HEREIN, EXCEED THE PRICE OF THE GOODS UPON WHICH SUCH LIABILITY IS BASED.

* It is the end user's responsibility to confirm that items intended for use satisfy local codes and standards.

